

# 3020G

# 使用说明书

---

在使用缝纫机之前请阅读本使用说明书。  
请将本使用说明书放在便于查阅的地方保管。

---

直接驱动式  
程序电脑花式机

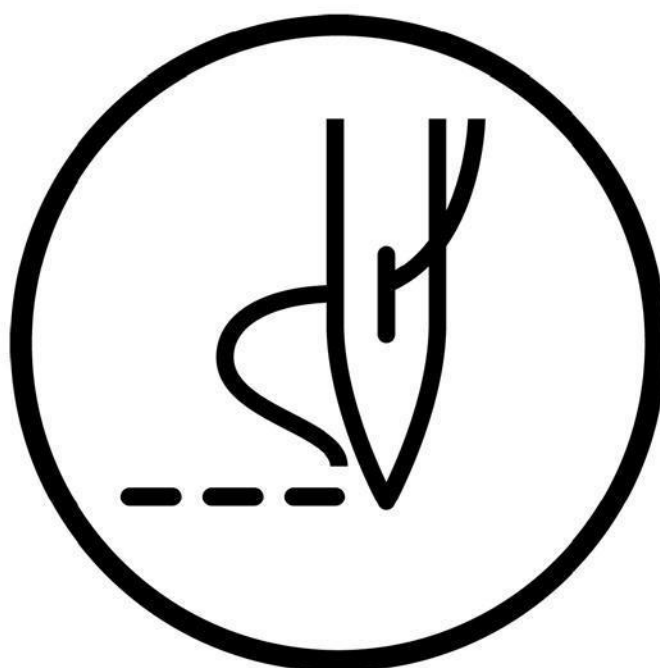

十分感谢您购买我公司工业缝纫机。  
在使用缝纫机之前，请仔细阅读<为了您的安全使用>和使用说明。



工业缝纫机的特性之一，因为要在机针和挑线杆等运动零部件附近进行操作，而这些零部件很容易引起受伤的危险，所以请在受过培训的人或熟练人员的安全操作知识的指导下，正确地使用本缝纫机。

## 为了您的安全使用



### [1] 安全使用的标记及其意义

本使用说明书及产品所使用的标记和图案记号是为了您的安全而正确地使用产品，防止您及其他人受到危害和损害。表示方法及含意如下。

#### 标记

|  |                                     |
|--|-------------------------------------|
|  <b>危险</b>  | 如果忽视此标记而进行了错误的操作，肯定会引起人员死亡或重伤。      |
|  <b>注意</b> | 如果忽视此标记而进行了错误的操作，有可能会引起人员受伤及造成设备损坏。 |

#### 图案和符号

-  .....该符号(△)表示“应注意事项”。  
三角中的图案表示必须要注意的实质内容。  
(例如，左边的图案表示“当心受伤”)
-  .....该符号(⊘)表示“禁止”。
-  .....该符号(●)表示“必须”。  
圆圈中的图案表示必须要做的事情的实质内容。  
(例如，左边的图案表示“必须接地”。)

## [2] 安全注意事项

### 危险



打开控制箱盖时，先关闭电源开关并将电源插头从插座上拔下后，至少等待 5 分钟后，再打开控制箱盖。触摸带有高电压的区域将会造成人员受伤。

### 注意

#### 使用环境



应避免在强电气干扰源(如高频焊机)的附近使用本缝纫机。

强电气干扰源可能会影响缝纫机的正确操作。



缝纫机可以在电源电压的波动范围小于额定电压的±10% 以内的环境下使用。

电压大幅度的波动会影响缝纫机的正确操作。



电源容量应大于缝纫机的消耗电量。电源容量不足会影响缝纫机的正确操作。



压缩空气的供气量应大于缝纫机所要求的总耗气量。压缩空气的供气量不足可能会导致缝纫机的操作不正常。



环境温度应在 5℃~35℃ 的范围内使用。低温或高温会影响缝纫机的正确操作。



相对湿度应在 45%~85% 的范围内，并且设备内不会形成结露的环境下使用。干燥或多湿的环境和结露会影响缝纫机的正确操作。



万一发生雷电暴风雨时，关闭电源开关，并将电源插头从插座上拔下。雷电可能会影响缝纫机的正确操作。

#### 安 装



请让受过培训的技术人员来安装缝纫机。



请委托购买商店或电气专业人员进行电气配线。



缝纫机质量约为 160kg。

请使用吊车或起重机等，来安装缝纫机和调整工作台面的高度。

如果由人工来搬运的话，易引起腰痛等及产生受伤的原因。



安装完成前，请不要连接电源。

如果误踩了脚踏开关，缝纫机动作会导致受伤。



缝纫机头倒下或竖起时，请用双手进行操作。

另外在缝纫机头倒下的状态下，请不要用力压缝纫机。如缝纫机失去平衡，缝纫机头滑落到地上是造成受伤或缝纫机损坏的原因。



必须接地。

接驳地线不牢固，是造成触电或误动作的原因。



所有电缆应固定在离活动部件至少 25mm 以外处。另外，不要过度弯曲电缆或用卡钉固定得过紧。



会引起火灾或触电的危险。



请在机头上及马达上安装安全罩壳。

如果使用带小脚轮的工作台，则应该固定小脚轮，使其不能移动。



工作台的高度请使用 84cm 以下的工作台，如果工作台过高一旦失去平衡缝纫机倒下，是造成受伤或缝纫机损坏的原因。











使用润滑油及黄油时，务必戴好保护眼镜和保护手套等，以防润滑油及黄油落入眼中或沾在皮肤上，这是引起发炎的原因。

另外，润滑油及黄油不能饮用，否则会引起呕吐和腹泻。



将油放在儿童拿不到的地方。

## ⚠ 注意

### 缝 纫

-  本缝纫机仅限于接受过安全操作培训的人员使用。
-  本缝纫机不能用于除缝纫外的任何其他用途。
-  使用缝纫机时必须戴上保护眼镜。  
如果不戴保护眼镜，断针时就会有危险，机针的折断部分可能会弹入眼睛并造成伤害。
-  发生下列情况时，请切断电源。  
否则误踩了脚踏开关时，缝纫机动作会导致受伤。
  - 机针穿线时
  - 交换梭芯和机针时
  - 缝纫机不使用，或人离开缝纫机时
-  如果使用带小脚轮的工作台，则应该固定小脚轮使其不能移动。
-  为了安全起见，在使用本缝纫机之前，请安装保护装置。  
如果未安装这些安全装置就使用缝纫机，会造成人身伤害及缝纫机损坏。
-  缝纫过程中，不要触摸任何运动部件或将物件靠在运动部件上，因为这会导致人员受伤或缝纫机损坏。
-  如果缝纫机操作中发生误动作，或听到异常的噪音或闻到异常的气味，应立即切断电源。然后请与购买商店或受过培训的技术人员联系。
-  如果缝纫机出现故障，请与购买商店或受过培训的技术人员联系。

### 清 洁

-  清洁前请关闭电源开关。  
否则如果误踩了脚踏开关，缝纫机动作会导致受伤。
-  使用润滑油及黄油时，务必戴好保护眼镜和保护手套等，以防润滑油及黄油落入眼中或沾在皮肤上，这是引起发炎的原因。  
另外，润滑油及黄油不能饮用，否则会引起呕吐和腹泻。  
将油放在儿童拿不到的地方。

### 维 护 和 检 查

-  只有经过训练的技术人员才能进行缝纫机的维修、保养和检查。
-  与电气有关的维修、保养和检查请委托购买商店或电气专业人员进行。
-  发生下列情况时，请关闭电源。并拔下电源线插座。  
否则误踩了脚踏开关时，缝纫机动作会导致受伤。
  - 检查、调整和维修
  - 更换旋梭等易损零部件
-  在检查、调整和修理任何使用气动装备之前，请先断开气源，并等压力表指针下降到“0”为止。
-  缝纫机头倒下或竖起时，请用双手进行操作。  
另外在缝纫机头倒下的状态下，请不要用力压缝纫机。如缝纫机失去平衡，缝纫机头滑落到地上是造成受伤或缝纫机损坏的原因。
-  在必须接上电源开关和气源开关进行调整时，务必十分小心遵守所有的安全注意事项。
-  请使用兄弟工业公司指定的更换零部件。
-  取下的安全保护装置，必须要安装回去。且请务必安装在原位上，并检查能否正常的发挥作用。
-  未经授权而对缝纫机进行改装而引起的缝纫机损坏不在保修范围内。

## [3] 警告标签

★ 缝纫机上有下列警告标签。

当使用缝纫机时，请遵守标签上的说明。

如果标签脱落或模糊不清，请和最近的本公司经销商联系。

1

|   |  |   |
|---|--|---|
|   | <b>▲ 危険 ▲ 危険</b>   |   |
|   | 高電圧部分にふれて、大けがをすることがある。電源を切り、5分たってからカバーをはずすこと。  | 触摸高压电部分，会导致受伤。在切断电源5分钟后，再开启盖罩。  |
| <b>▲ DANGER</b>   | <b>▲ GEFAHR</b>  | <b>▲ PELIGRO</b>  |
| Hazardous voltage will cause injury. Turn off main switch and wait 5 minutes before opening this cover. | Hochspannung verletzungsgefahr! Bitte schalten sie den hauptschalter aus und warten sie 5 minuten, bevor sie diese abdeckung öffnen. | Un voltage non adapte provoque des blessures. Eteindre l'interrupteur et attendre 5 minutes avant d'ouvrir le capot.                |
|   |  | Un voltaje inadecuado puede provocar las heridas. Apagar el interruptor principal y esperar 5 minutos antes de abrir esta cubierta. |

2

|  |   |
|--|---|
|  | <b>▲ 注意</b>   |
|  | 触摸运动部分，易造成受伤。所以在装上安全保护装置后，再进行缝纫操作。在切断电源后，进行穿线，更换梭芯，机针和做清扫，调整工作。 |
| <b>▲ CAUTION</b>   |   |
| Moving parts may cause injury. Operate with safety devices. Turn off main switch before threading, changing bobbin and needle, cleaning etc. |   |

3 请注意别让运动部夹住您的手指。

4 **PE** 必须接地。  
如果接驳地线不牢固，是造成触电或误动作的原因。

5 表示回转方向

安全装置：

- 护眼板
- 护指器
- 挑线杆防护罩
- 马达盖
- X 方向马达盖
- 松线电磁铁罩
- 内盖
- 外盖
- 中间盖
- 固定盖
- 后盖

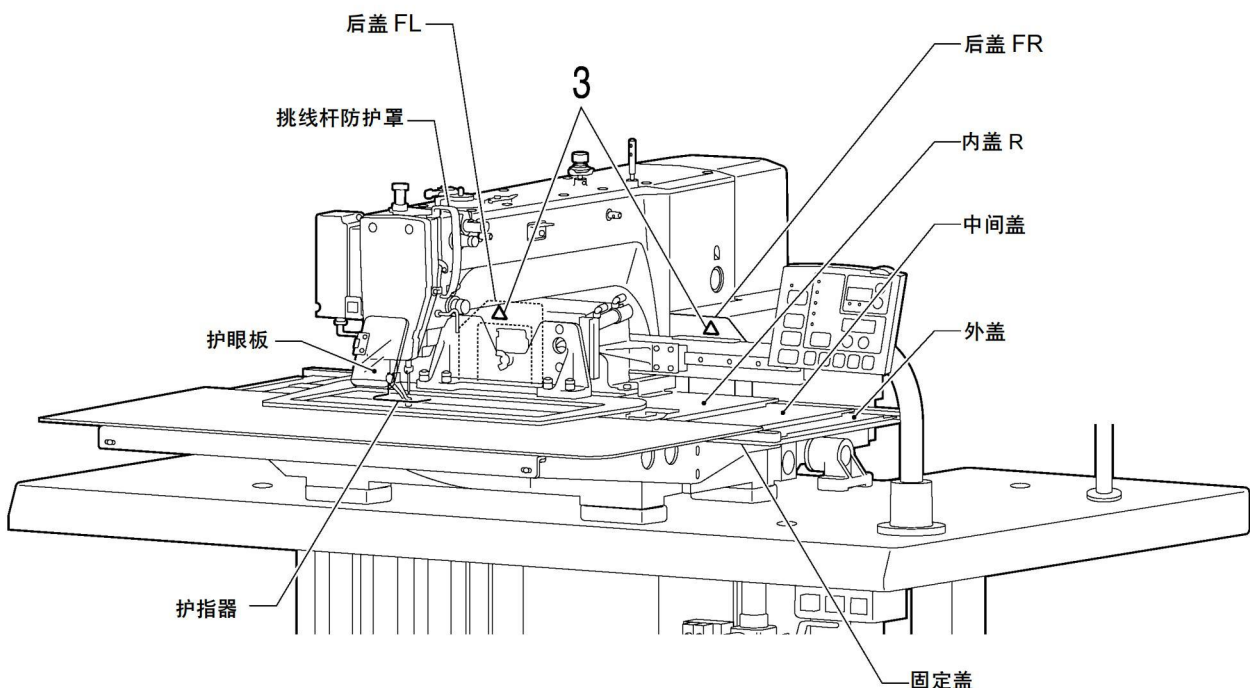

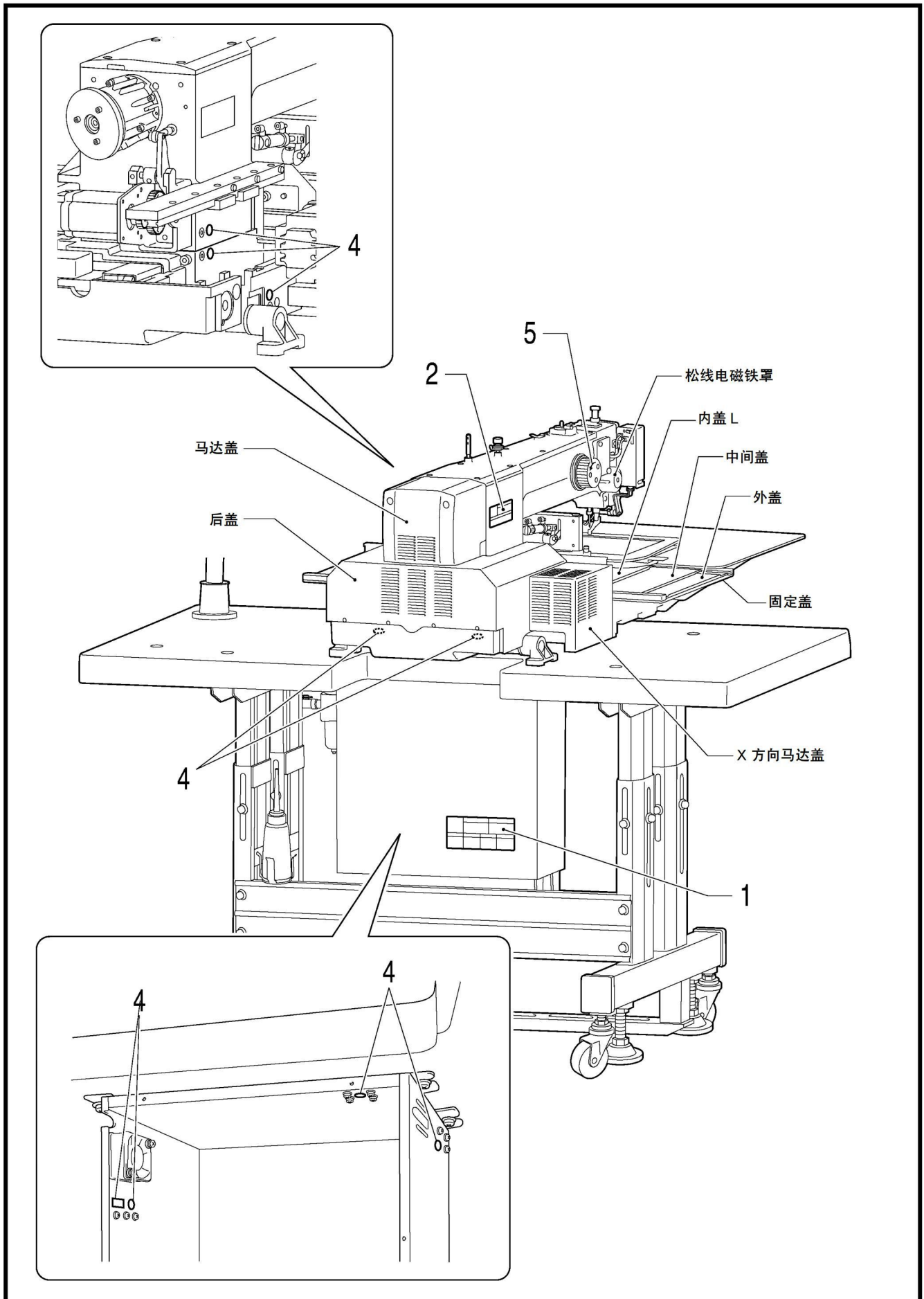

# 目 录

|                            |    |                        |    |
|----------------------------|----|------------------------|----|
| 1. 主要零部件的名称.....           | 1  | 7. 保养 .....            | 21 |
| 2. 规格 .....                | 2  | 7-1. 旋梭的清扫.....        | 21 |
| 3. 工作台板加工图.....            | 3  | 7-2. 废油.....           | 21 |
| 4. 安装方法 .....              | 4  | 7-3. 调节器的点检.....       | 22 |
| 4-1. 头部固定用螺栓的拆除方法 .....    | 4  | 7-4. 控制箱进气口的清扫 .....   | 22 |
| 4-2. 控制箱的安装方法 .....        | 5  | 7-5. 护眼板的清洁 .....      | 22 |
| 4-3. 油盘和缝纫机头部支撑座的安装方法..... | 6  | 7-6. 机针的检查.....        | 22 |
| 4-4. 缝纫机头部的安装方法.....       | 6  | 7-7. 加油.....           | 22 |
| 4-5. 缝纫机头的倒下及竖起的方法.....    | 7  | 8. 标准调整 .....          | 23 |
| 4-6. 减震器的安装方法.....         | 8  | 8-1. 挑线簧的调整 .....      | 23 |
| 4-7. 线缆和空气管的固定方法 .....     | 9  | 8-2. 机壳线导向R的调整 .....   | 24 |
| 4-8. 护眼板的安装方法 .....        | 10 | 8-3. 针杆高度的调整 .....     | 24 |
| 4-9. 线架的安装方法 .....         | 10 | 8-4. 针杆上升量的调整.....     | 24 |
| 4-10. 供油 .....             | 11 | 8-5. 梭托导针部的调整.....     | 25 |
| 4-11. 安全开关的确认 .....        | 12 | 8-6. 针隙的调整 .....       | 25 |
| 5. 缝纫前的准备 .....            | 13 | 8-7. 旋梭导线器的调整 .....    | 25 |
| 5-1. 机针的安装方法 .....         | 13 | 8-8. 旋梭供油量的调整 .....    | 26 |
| 5-2. 2连脚踏开关的操作方法.....      | 13 | 8-9. 动刀的位置调整.....      | 27 |
| 5-3. 面线的穿法.....            | 14 | 8-10. 动刀和定刀的更换方法 ..... | 29 |
| 5-4. 底线的绕线方法 .....         | 16 | 8-11. 扫线器的调整 .....     | 30 |
| 5-5. 梭芯套的装取方法.....         | 17 | 8-12. 间歇压脚的安装位置.....   | 31 |
| 5-6. 缝纫张力 .....            | 18 | 8-13. 间歇压脚行程的变换.....   | 31 |
| 5-6-1. 底线的张力 .....         | 18 | 8-14. 压脚上升量的调整 .....   | 33 |
| 5-6-2. 面线的张力 .....         | 19 | 8-15. 空气压力的调整.....     | 33 |
| 6. 缝纫.....                 | 19 | 9. 故障检修.....           | 34 |
| 6-1. 缝纫的方法 .....           | 19 |                        |    |
| 6-2. 暂停开关的使用方法.....        | 20 |                        |    |
| 6-3. 扫线用开关的使用方法 .....      | 20 |                        |    |

# 1. 主要零部件的名称

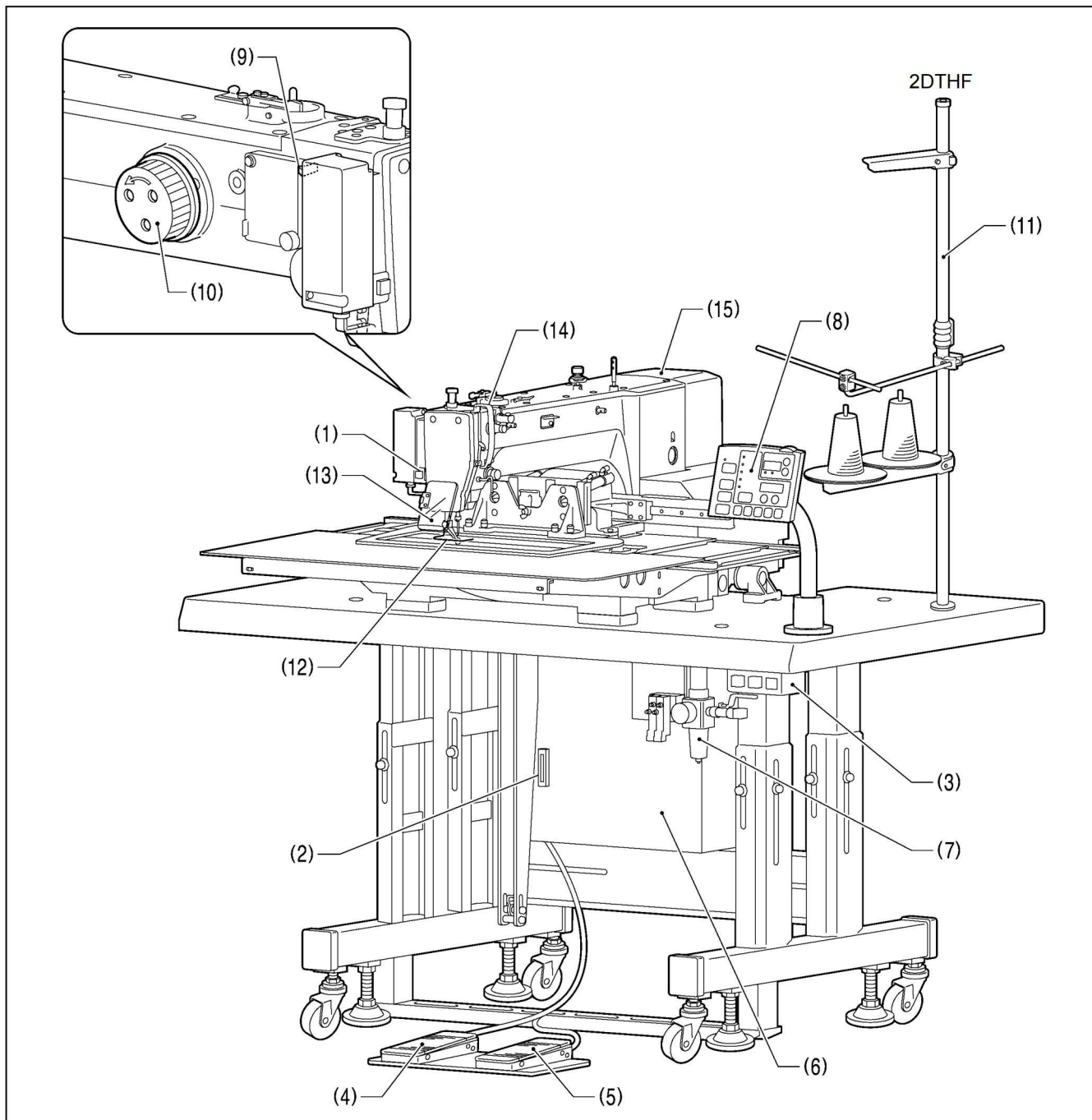

- (1) 暂停开关
- (2) CF 卡插入口
- (3) 电源开关
- (4) 压脚开关
- (5) 启动开关
- (6) 控制箱
- (7) 电磁阀
- (8) 操作盘
- (9) 扫线用开关
- (10) 手轮
- (11) 线架

### 安全保护装置

- (12) 护指器
- (13) 护眼板
- (14) 挑线杆防护罩
- (15) 马达罩



## 2. 规格

|           |   |
|-----------|---|
| 使用的缝纫机    | 平缝花样缝缝纫机(带大旋梭)  |
| 线迹形式      | 单针平缝  |
| 最高缝纫速度    | 2,700rpm  |
| 缝纫尺寸(X×Y) | 最大300×200mm   |
| 送布驱动方式    | 间歇送布(脉冲马达驱动)  |
| 针迹节距      | 0.05~12.7mm   |
| 针数        | 内存500,000针(※)   |
| 最大针数      | 20,000针(1个程序)   |
| 存储可能缝纫的数据 | 内存:512种类(※)   |
| 抬压脚方式     | 空压式   |
| 压脚上升量     | 最大30mm  |
| 2段压脚      | 左右一体式压脚   |
| 间歇压脚上升量   | 22mm  |
| 间歇压脚行程    | 2~4.5mm, 4.5~10mm或0(出厂时3mm)                             |
| 使用的旋梭     | 半回转2倍旋梭(标准旋梭另买)   |
| 扫线装置      | 标准装备  |
| 切线装置      | 标准装备  |
| 数据存储方式    | 内存(快擦写存储器), CF卡(32MB~2GB)<br>[选购件]3.5磁盘 2HD/1.44MB, 2DD |
| 用户程序数     | 999   |
| 循环程序数     | 9   |
| 马达        | AC伺服马达750W  |
| 质量        | 头部:约160kg,操作盘:约0.6kg<br>控制箱:14.2~16.2kg(根据电压不同而不同)      |
| 电源        | 单相220V,3相220V/380V/400V 500VA                           |
| 空气压力      | 0.5MPa 1.8l/min   |

※ 根据各个程序的针数的不同,能够存储的缝纫数据和针数也有所不同的。

### 3. 工作台板加工图

- 工作台板的厚度应达 50mm，能够承受缝纫机的重量，并经的起缝纫机的震动。
- 如使用脚轮时，请使用能够承受缝纫机重量的脚轮。
- 请确认控制箱应离开机脚 10mm 以上。如果控制箱过于靠近机脚，则可能会引起缝纫机的误动作。

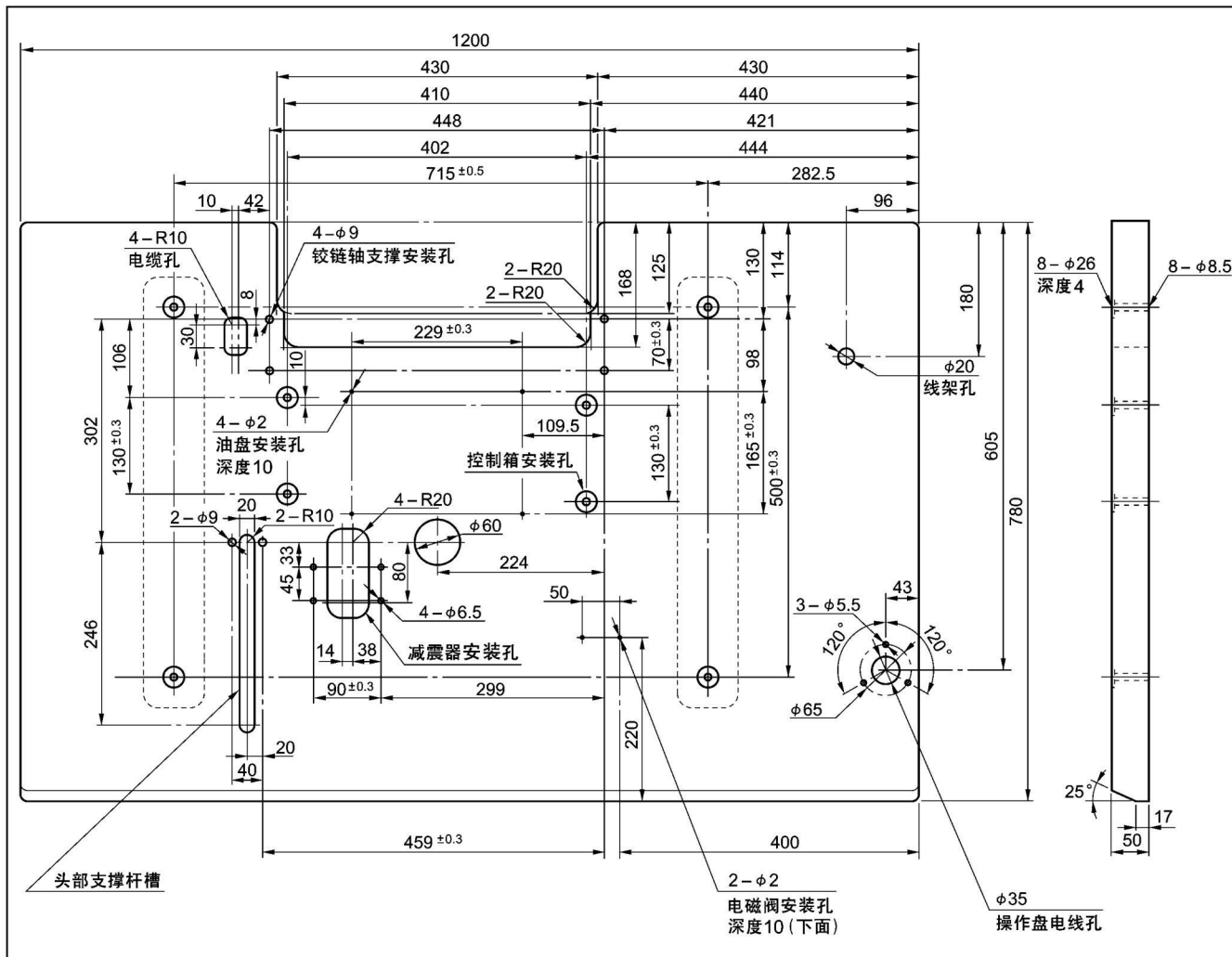

## 4. 安装方法

### 注意

- ⊘ 请让受过培训的技术人员来安装缝纫机。
- ⚠ 请委托购买商店或电气专业人员进行电气配线。
- ⚠ 缝纫机质量约为 160kg。
- ⚠ 请使用吊车或起重机等，来安装缝纫机和调整工作台面的高度。  
如果由人工来搬运的话，易引起腰痛等及产生受伤的原因。
- ⊘ 安装完成前，请不要连接电源。
- ⊘ 如果误踩了脚踏开关，缝纫机动作会导致受伤。
- ⚠ 如果使用带小脚轮的工作台，则应该固定小脚轮，使其不能移动。
- ⚠ 工作台的高度请使用 84cm 以下的工作台，如果工作台过高一旦失去平衡缝纫机倒下，是造成受伤或缝纫机损坏的原因。
- ⚠ 缝纫机头倒下或竖起时，请用双手进行操作。  
另外在缝纫机头倒下的状态下，请不要用力压缝纫机。如缝纫机失去平衡，缝纫机头滑落到地上是造成受伤或缝纫机损坏的原因。
- ⚠ 所有电缆应固定在离活动部件至少 25mm 以外处。  
另外，不要过度弯曲电缆或用卡钉固定得过紧。会引起火灾或触电的危险。
- ⊘ 必须接地。
- ⚠ 接驳地线不牢固，是造成触电或误动作的原因。
- ⚠ 请在机头上及马达上安装安全罩壳。

#### 未安装在缝纫机工作台上的情况

请参考下一页的「4-2. 控制箱的安装方法」的顺序进行。

#### 已安装在缝纫机工作台上后交货的情况

请按标题后的[1]到[15]项目号的顺序进行。

#### 4-1. 头部固定用螺栓的拆除方法

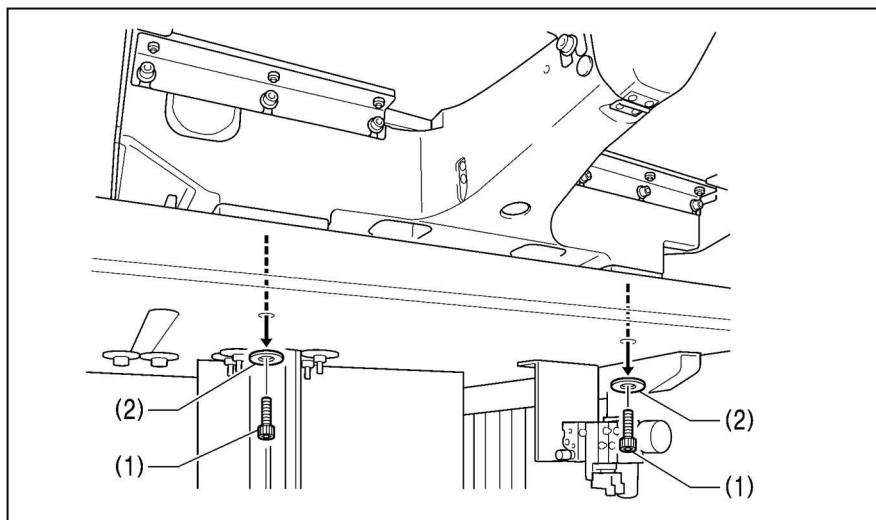

对于缝纫机已安装在工作台上后交货的规格，先将头部固定用螺栓(1)[2个]和垫圈(2)[2片]拆下。

## 4-2. 控制箱的安装方法

### ⚠ 注意



因为控制箱很重，安装工作必须由两人以上来完成。

另外，请注意不可使控制箱滑落。

会砸伤自己的脚以及会造成控制箱故障的原因。

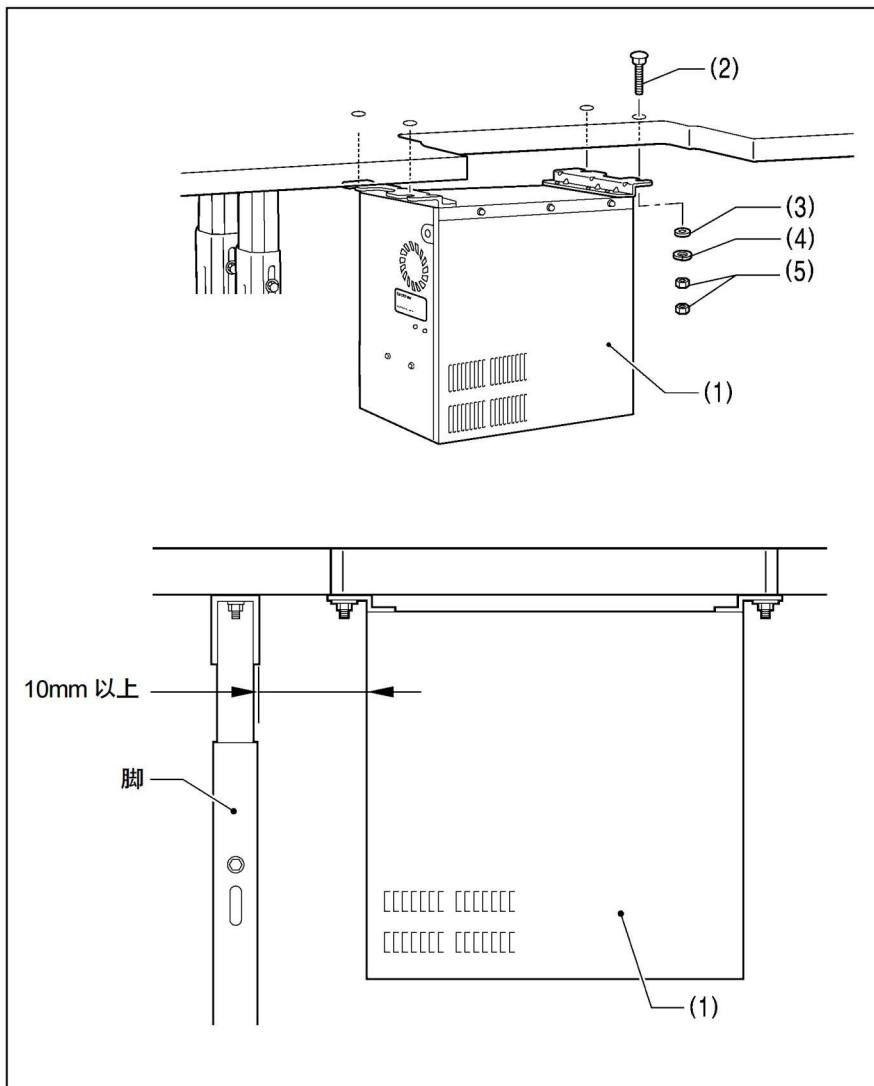

\* 如果缝纫机已安装在工作台上时，倒下缝纫机头。  
(具体参考「4-5. 缝纫机头的倒下及竖起的方法」)

- (1) 控制箱
- (2) 螺栓 [4 个]
- (3) 垫圈 [4 片]
- (4) 弹簧垫圈 [4 片]
- (5) 螺母 [8 个]

### [注意]

请确认控制箱(1)应安装在离台脚10mm 以上处。控制箱(1)离台脚太接近的话，易使缝纫机产生错误动作。

## 4-3. 油盘和缝纫机头部支撑座的安装方法

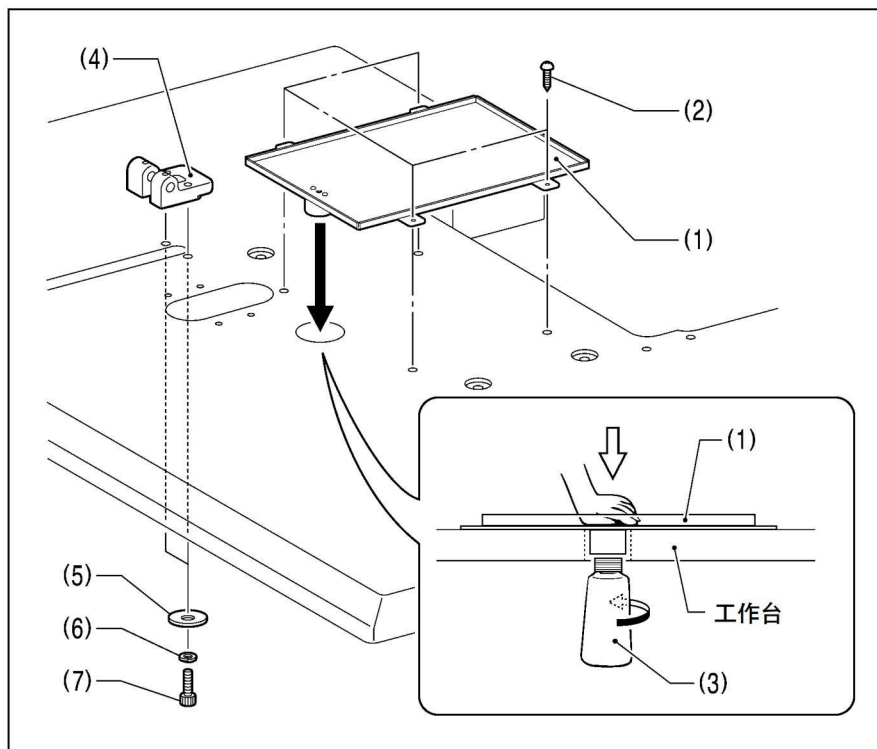

- (1) 油盘
- (2) 木螺钉[4个]
- (3) 油壶
- (4) 头部支撑座
- (5) 垫圈[2片]
- (6) 弹簧垫圈[2片]
- (7) 螺栓[2个]

## 4-4. 缝纫机头部的安装方法

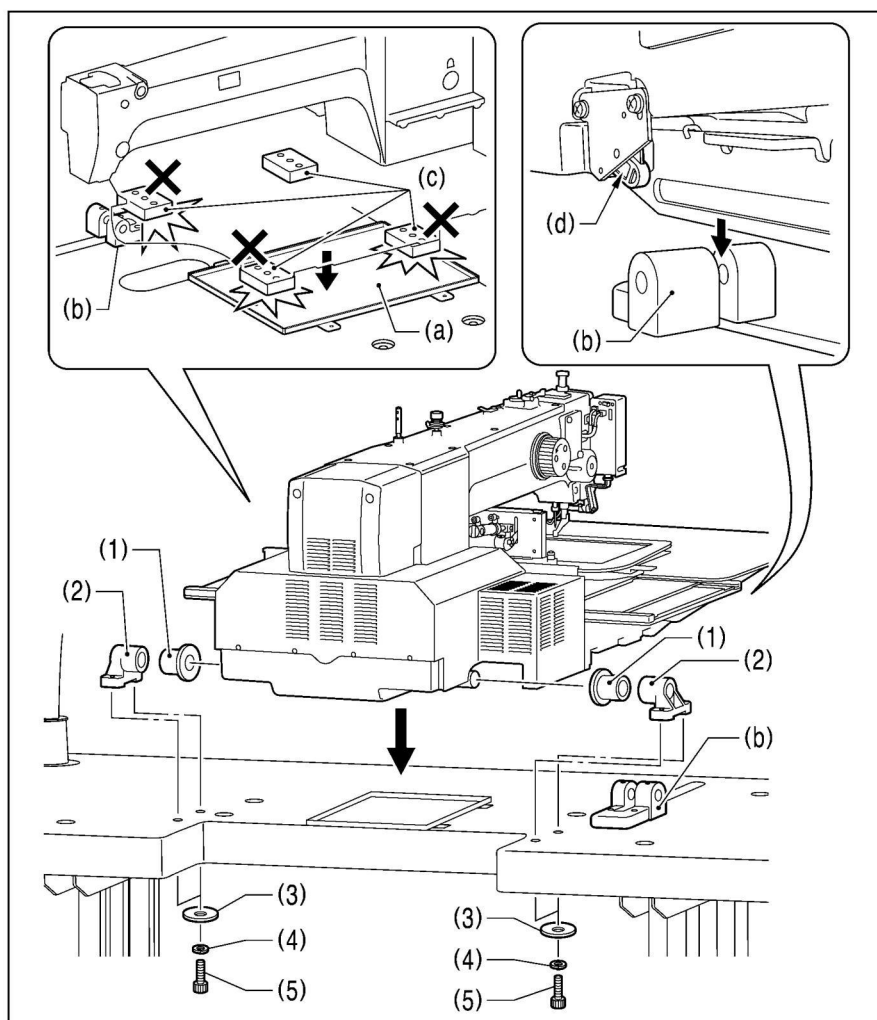

1. 将缝纫机安装到工作台上。

## 【注意】

- 请使用吊车或起重机等，来安装缝纫机。
- 将缝纫机头部放到工作台上时，请注意下列事项。
  - ！ 缝纫机头部和工作台之间不可夹住电缆线之类。
  - ！ 不可将缝纫机头部的防震垫(c) 撞到或放到油盘(a)及缝纫机头部支撑座(b)的上面。
  - ！ 安全开关杆的侧面(d)不可撞到缝纫机头部支撑座(b)。

- (1) 橡皮轴套[2个]
- (2) 铰链轴支架[2个]
- (3) 垫圈[4片]
- (4) 弹簧垫圈[4片]
- (5) 螺栓[4个]

(下一页继续)

#### 4. 安装方法

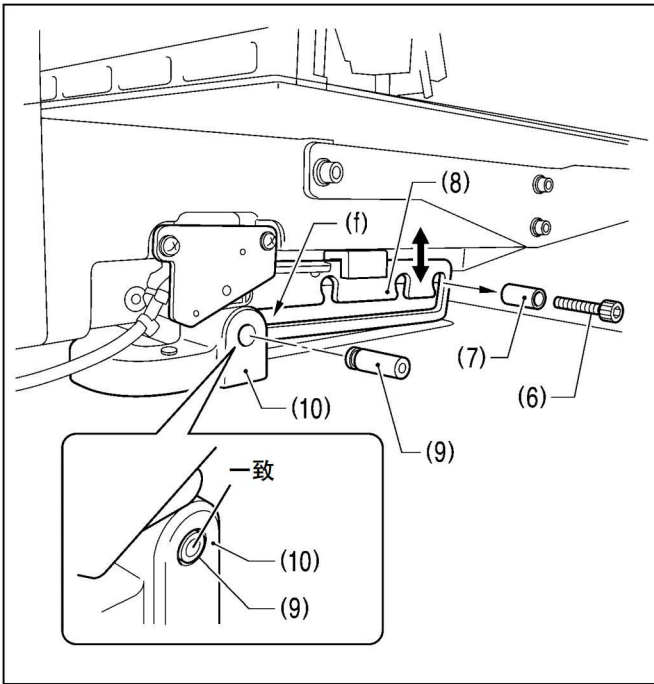

2. 缝纫机安装到工作台上后，拆下螺栓(6)和垫圈(7)。
  - \* 取下的螺栓(6)和垫圈(7)在固定头部支撑杆(8)时还要使用的，所以必须妥善保管。
3. 头部支撑杆轴(9)穿过头部支撑座(10)的孔和头部支撑杆(8)的槽(f)，并一直压到和头部支撑座(10)的表面一致为止。
  - \* 如果头部支撑杆轴(9)不能穿进头部支撑杆(8)的槽(f)时，可将头部支撑杆(8)的一端进行上下移动后，再穿入头部支撑杆轴(9)。

#### 4-5. 缝纫机头的倒下及竖起的方法

### ⚠ 注意



缝纫机头倒下或竖起时，请用双手进行操作。

另外在缝纫机头倒下的状态下，请不要用力压缝纫机。如缝纫机失去平衡，缝纫机头滑落到地上是造成受伤或缝纫机损坏的原因。



缝纫机头倒下时，必须使用头部支撑杆(1)的定位器。

如果不使用定位器，缝纫机自动复位造成夹伤手指等的原因。



放开定位器时，请一定要抓住捏手部(a)。

如果捏住(b)部的话，缝纫机头部竖起时头部支撑杆(1)和工作台会夹住手指，成为受伤的原因。

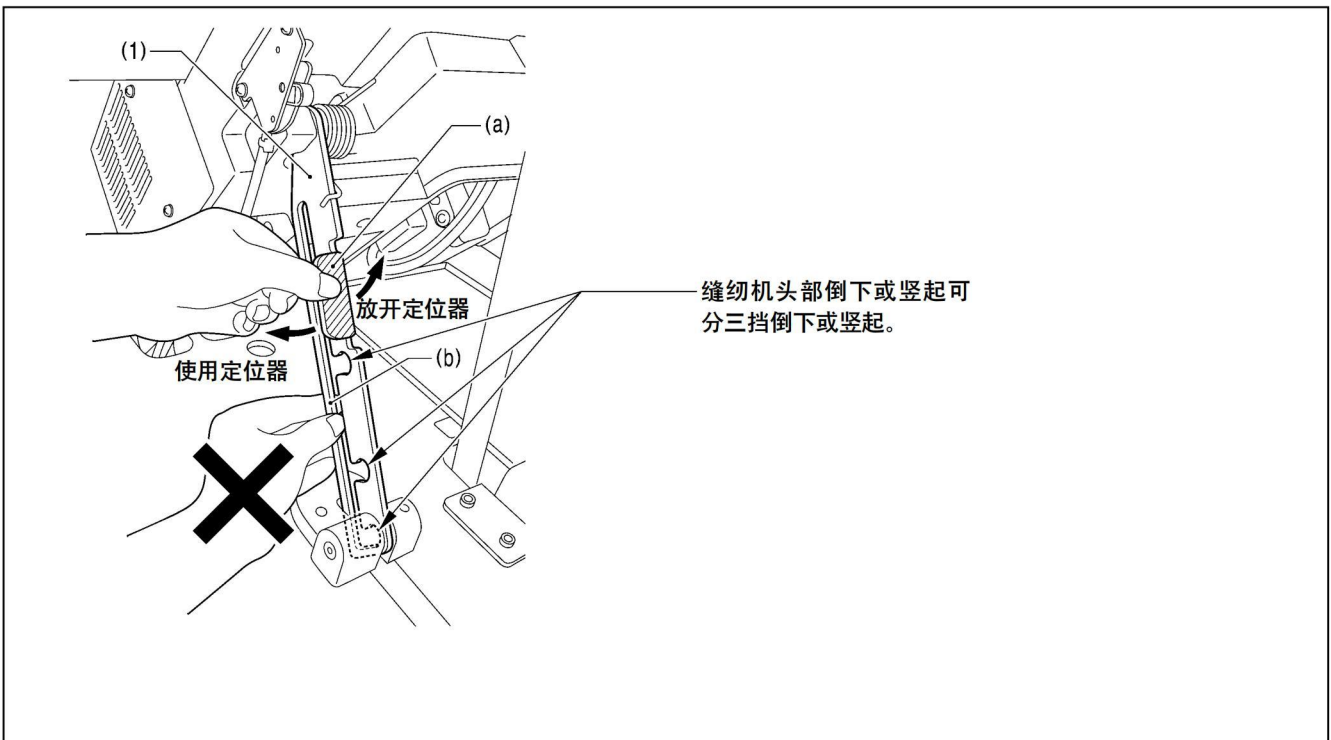

## 4-6. 减震器的安装方法

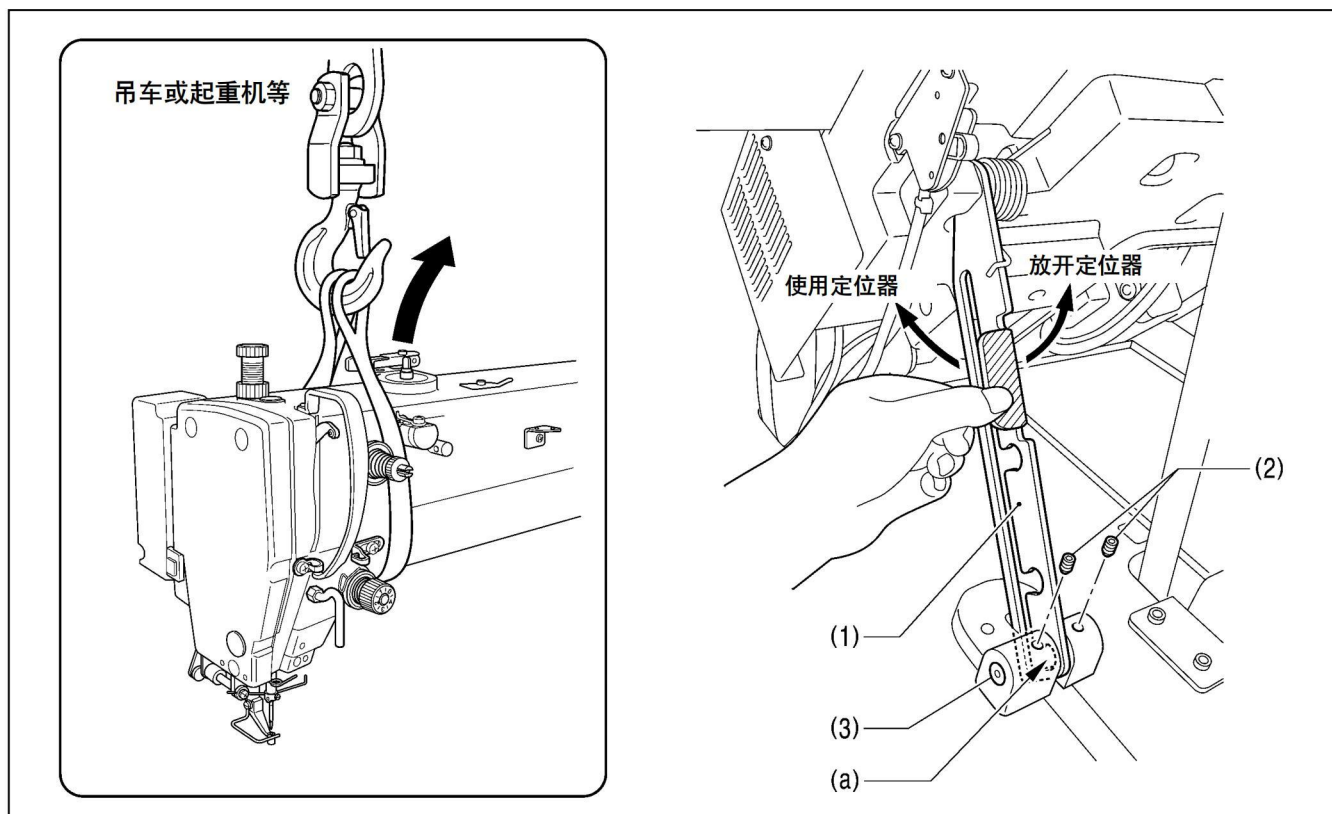

1. 倒下缝纫机头部，并使用头部支撑杆(1)将其固定在定位器(a)的位置。  
(参考「4-5. 缝纫机头的倒下及竖起的方法」)

**[注意]** 缝纫机头倒下时，请使用吊车或起重机等。

2. 拧紧螺钉(2)[2个]，固定头部支撑杆轴(3)。

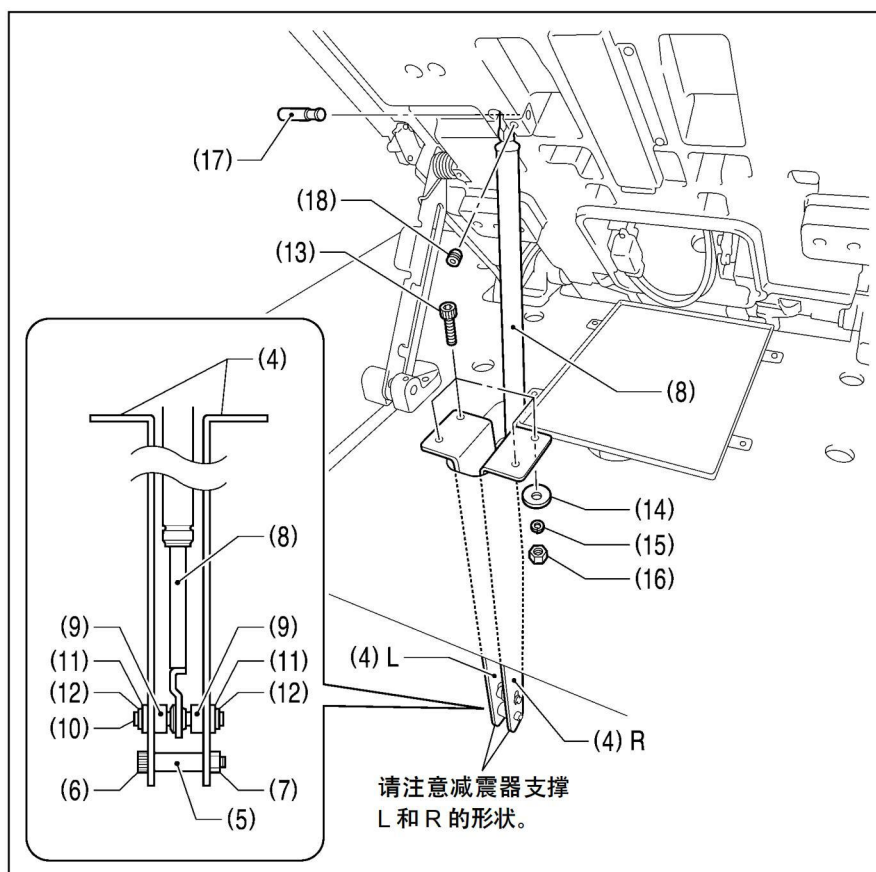

3. 安装减震器(8)。

- (4) 减震器支撑[L和R]
- (5) 垫圈
- (6) 螺栓
- (7) 螺母
- (8) 减震器
- (9) 轴套[2个]
- (10) 减震器轴D
- (11) 垫圈[2片]
- (12) 挡圈E[2片]
- (13) 螺栓[4个]
- (14) 垫圈[4片]
- (15) 弹簧垫圈[4片]
- (16) 螺母[4个]
- (17) 减震器轴U
- (18) 螺钉

\* 安装完减震器(8)后，将缝纫机头部慢慢竖起。  
(参考「4-5. 缝纫机头的倒下及竖起的方法」)

### 4-7. 线缆和空气管的固定方法

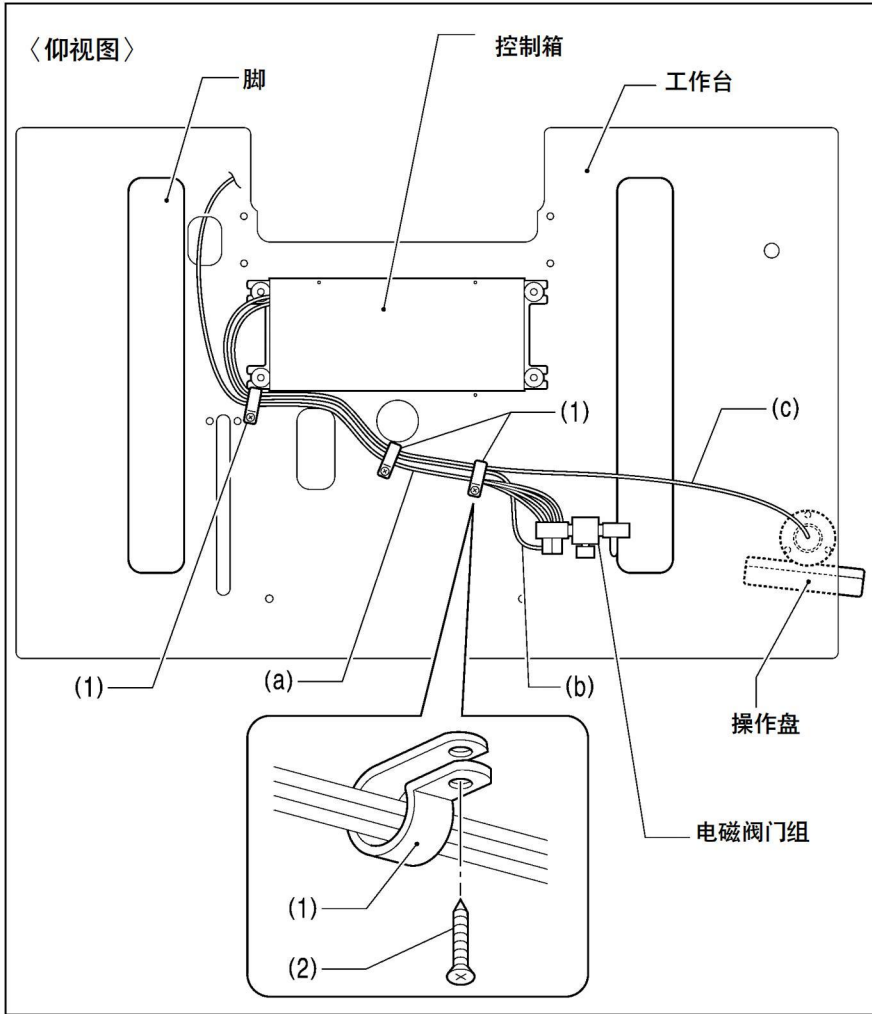

使用电线夹(1)[3个]将各空气管(a)、电磁阀门组的电线(b),操作盘电线(c)一起固定在工作台的下面。

- (1) 电线夹[3个]
- (2) 木螺钉[3个]

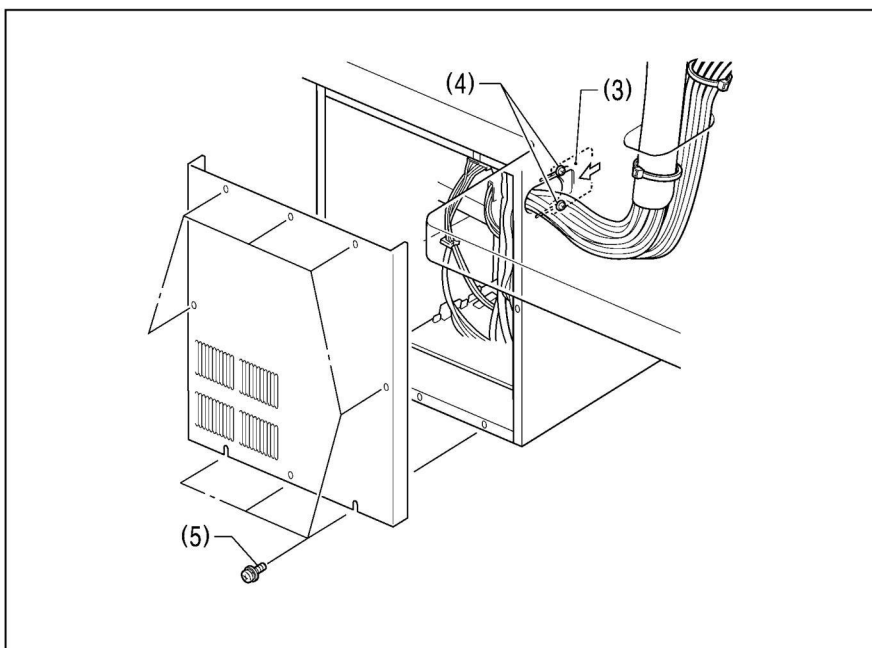

#### 〈电线的确认〉

1. 慢慢地将缝纫机头部倒下。  
(参考「4-5. 缝纫机头的倒下及竖起的方法」)
2. 确认各电线应没有被拉伸情况。
3. 将缝纫机头竖起,复位。
4. 按箭头方向关闭电线压板(3),然后拧紧固定螺钉(4)[2个]。

#### 〔注意〕

请一定关紧电线压板(3)。不可让异物或是小虫之类进入控制箱内。

5. 安装上控制箱的盖,使用固定螺钉(5)[8个]拧紧。此时请确认电线类等应没有被盖子夹住。



## 4-8. 护眼板的安装方法

**! 注意**

为了安全起见，在使用本缝纫机之前，请安装保护装置。  
如果未安装这些安全装置就使用缝纫机，会造成人身伤害及缝纫机损坏。

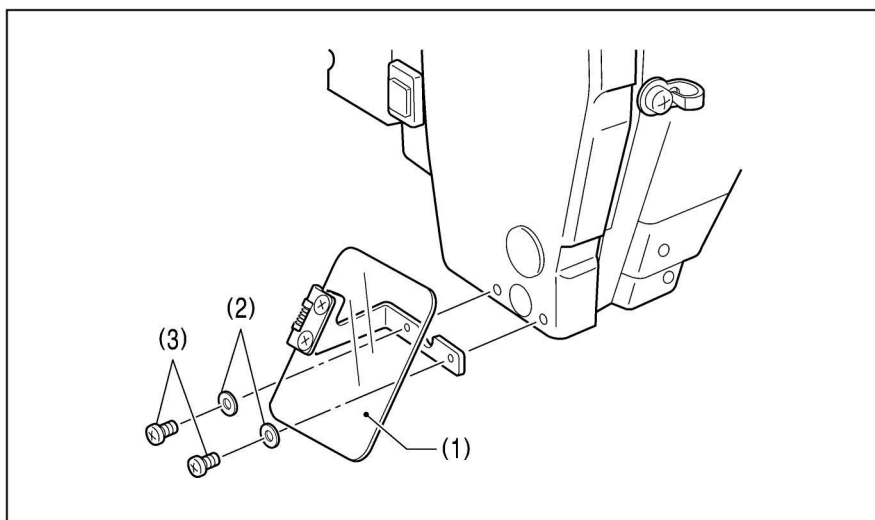

- (1) 护眼板组件
- (2) 垫圈 [2 片]
- (3) 螺钉 [2 个]

## 4-9. 线架的安装方法

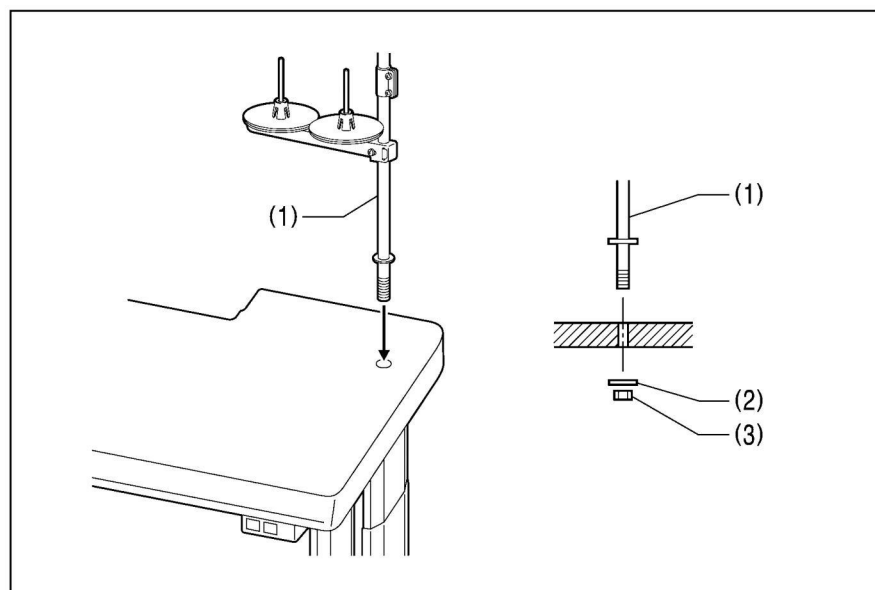

- (1) 线架

**[注意]**

安装上垫圈(2)，请拧紧螺母(3)使线架完全不能移动。

### 4-10. 供油

## ! 注意



在加油未完成前，请勿插上电源。  
如果误踩脚开关，缝纫机动作会导致受伤。



使用润滑油及黄油时，务必戴好保护眼镜和保护手套等，以防润滑油及黄油落入眼中或沾在皮肤上，这是引起发炎的原因。

另外，润滑油及黄油不能饮用，否则会引起呕吐和腹泻。  
将油放在儿童拿不到的地方。

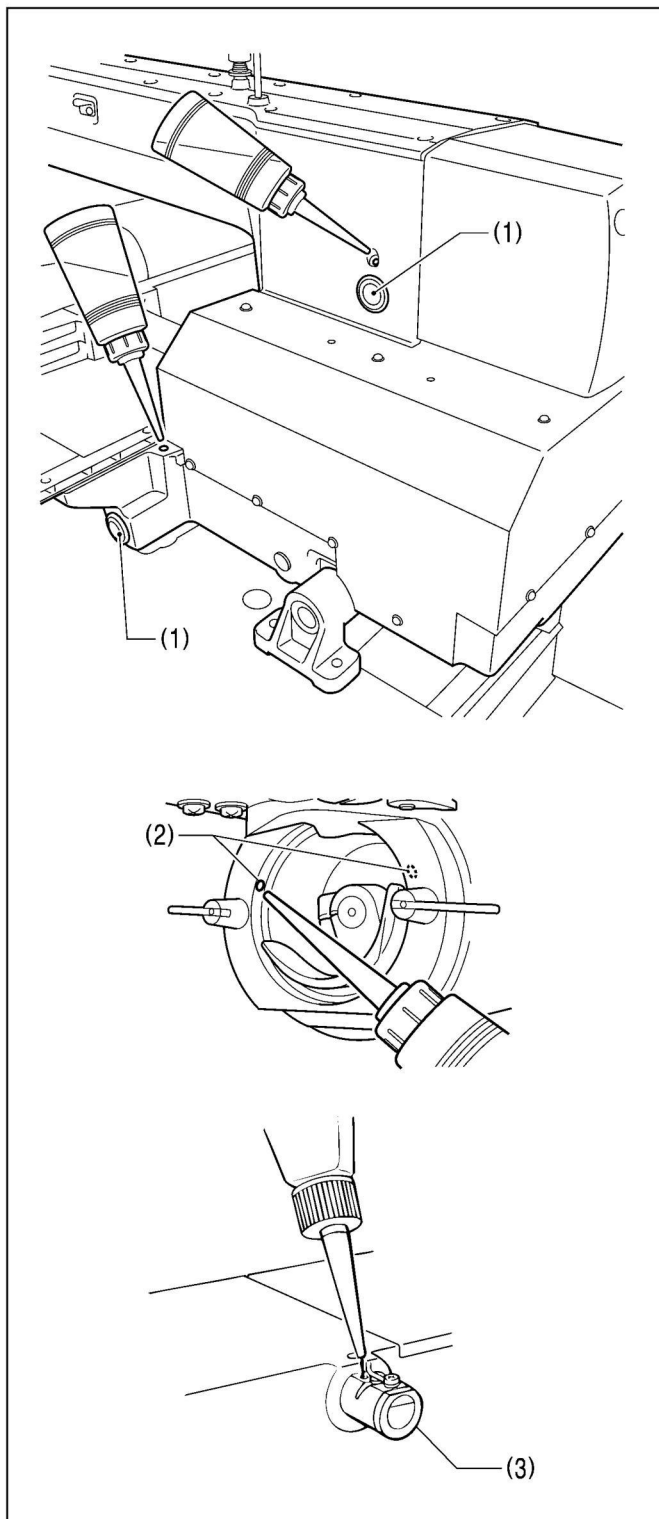

1. 向机壳侧面的油箱和底板侧面的油箱注油。

#### [注意]

当油面下降到油面指示窗(1)的 1/3 左右时，请务必加注机油。如果油面下降到油面指示窗(1)的 1/3 以下，则可能会成为机器烧伤等故障的原因。

2. 给大旋梭本体组件的 2 个孔(2)注入机油，使毛毡上含有微量的机油。

#### [注意]

如果大旋梭本体组件的毛毡上没有机油时，则可能会造成缝纫故障的原因。

3. 如果使用冷却液槽(3)时，请在槽中注入硅油(100mm<sup>2</sup>/s)。

(冷却液槽(3)的使用方法参考「5-3. 面线的穿法」)

## 4-11. 安全开关的确认

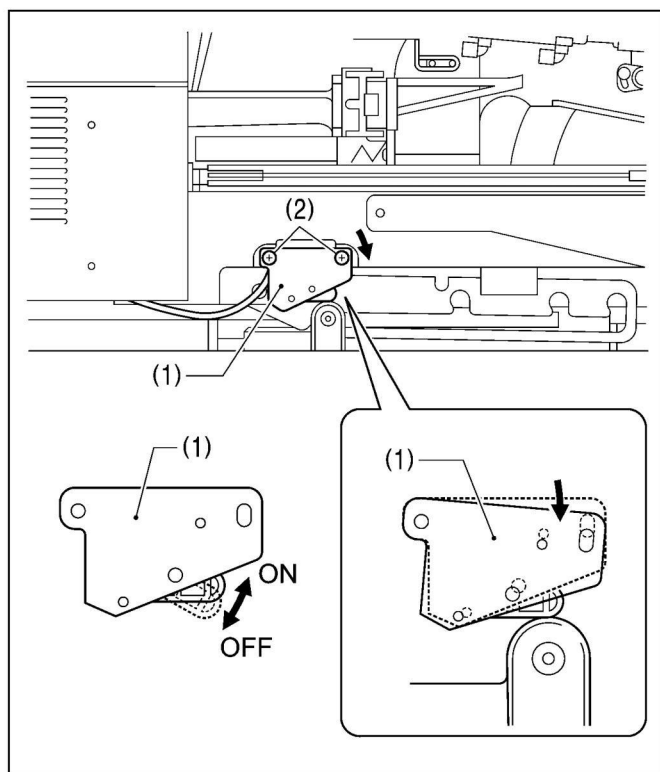

1. 如果缝纫机头是倒着的，可慢慢地将缝纫机头竖起，复位。（参考「4-5. 缝纫机头的倒下及竖起的方法」）
2. 接通电源。
3. 确认操作盘上没有表示错误 No. 。

如果安全开关(1)没有ON时会发生错误No.

请调整安全开关(1)的安装位置。

- 1) 关闭电源。
- 2) 松开螺钉(2)[2个]。
- 3) 在安全开关(1)的右侧完全被按下，安全开关(1)变成ON的位置后，拧紧螺钉(2)[2个]。
- 4) 接通电源，确认是否已没有错误No. 的表示。

## 5. 缝纫前的准备

### 5-1. 机针的安装方法



**注意**



安装机针时，请切断电源。

当误踩下脚踏开关时，缝纫机动作会导致人员受伤。

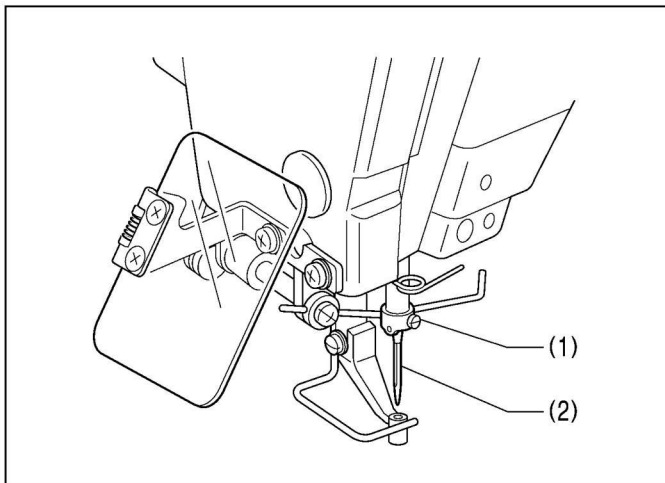

1. 松开螺钉(1)。
2. 机针(2)的长槽朝着正面，笔直插到底并用力拧紧螺钉(1)。

### 5-2.2 连脚踏开关的操作方法

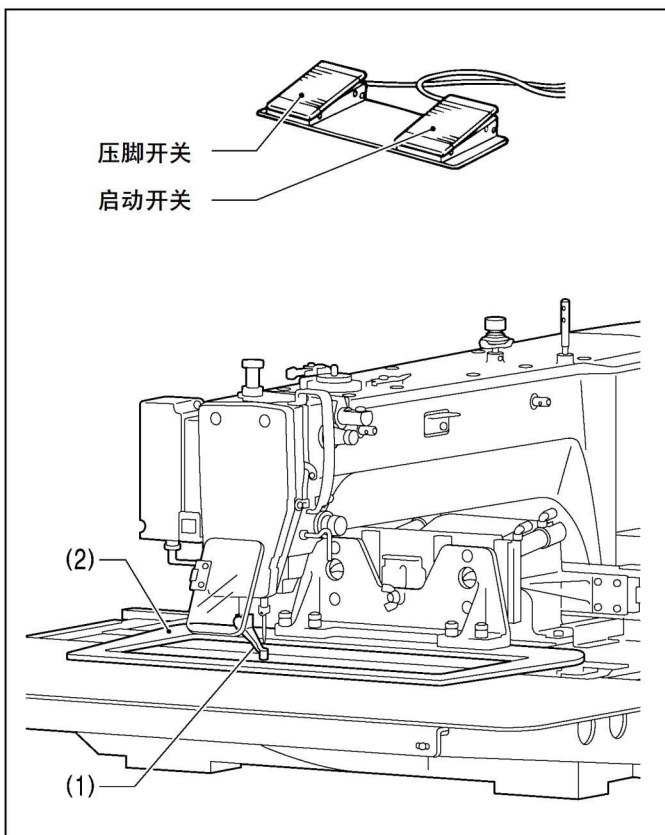

当踩下压脚开关(左侧)时压脚(1)和压脚板(2)下降，当踩下启动开关(右侧)时缝纫机启动。

\* 压脚板(2)的放下方法，使用存储器开关 No. 002 可以改变。(参考「7-3. 存储器开关一览表」)

## 5-3. 面线的穿法

请按下图所示序号正确地穿面线。

\*如果在穿线模式下进行穿线时，夹线盘(1)将变成打开状态，缝线就更加便于穿过。(参考下一页)

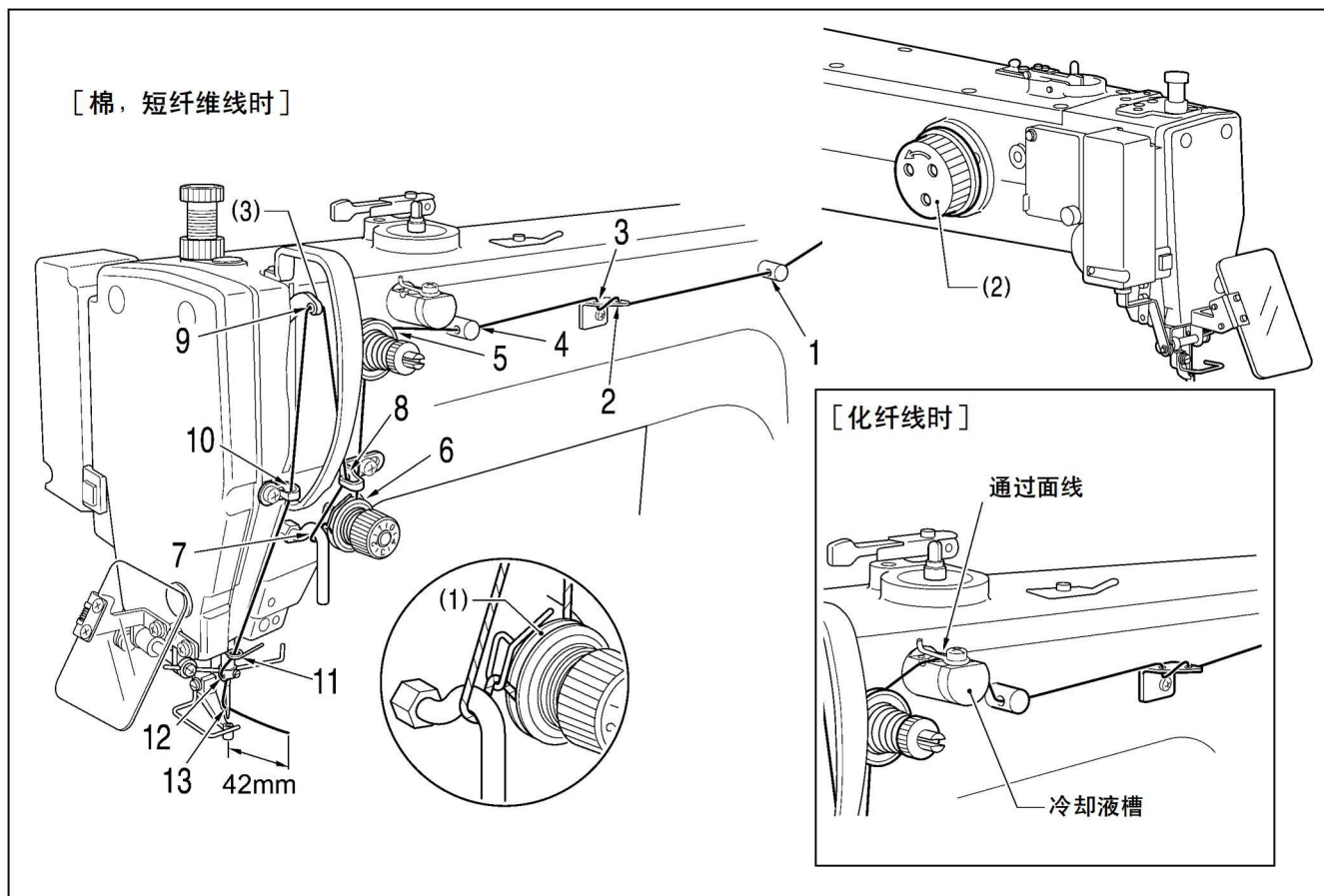





- 回转缝纫机手轮(2)，请将挑线杆(3)调到最高点后，进行穿线。  
(容易穿线，且可防止开始缝纫时的脱线。)
- 在线穿过机针后，从机针孔处留出线的长度为42mm左右。  
如留出的线过长有可能会打结。

## 5. 缝纫前的准备

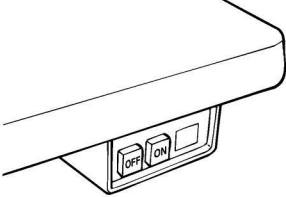
### <穿线模式>

在穿线模式下，即使踩下脚踏开关，缝纫机也不会启动，所以非常安全。

|   |   |
|---|---|
| 1 |  <p>接通电源。</p>  |
| 2 | <p>按回零键</p>  <p>按穿线键，同时键符改变。</p>   <ul style="list-style-type: none"><li>• 降下压脚。</li></ul> |
| 3 | <p>进行穿线</p>   |
| 4 | <p>穿线模式结束</p> <p>按穿线键，同时键符改变。</p>   <ul style="list-style-type: none"><li>• 压脚返回到进入穿线模式前的状态。</li></ul>  |

## 5-4. 底线的绕线方法

**! 注意**

在卷线过程中，不要触摸任何运动部件或将物件靠在运动部件上，因为这会导致人员受伤或缝纫机损坏。

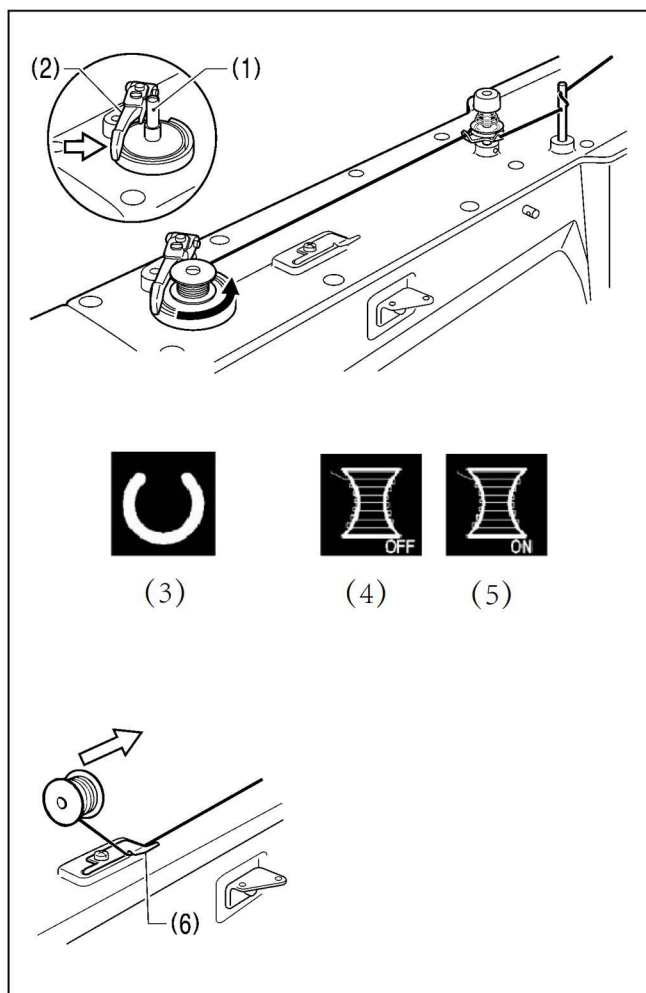

1. 将梭芯嵌入卷线轴(1)上。
2. 按图示进行穿线，将线在梭芯内绕几圈，然后压上梭芯压臂柄(2)。
3. 接通电源。
4. 按回零键(3)进行原点检测。
5. 确认机针不碰到压脚板。按绕线键(4)，使绕线键(4)切换成绕线键(5)，并处于“ON”状态，将脚踏开关踩到第2档位置，开始绕线。  
(2连脚踏开关时，踩下2连脚踏开关的启动开关)
6. 当绕线量达到一定的数量(梭芯外径的80%~90%)时应停止绕线，梭芯压臂柄(2)将自动返回(如果在中途踩下脚踏开关的启动开关，或按下绕线键(5)，使绕线键(5)切换成绕线键(4)，并处于“OFF”状态，则停止绕线)。
7. 取下梭芯，将线钩在切刀(6)上，朝箭头方向拉梭芯，将线割断。

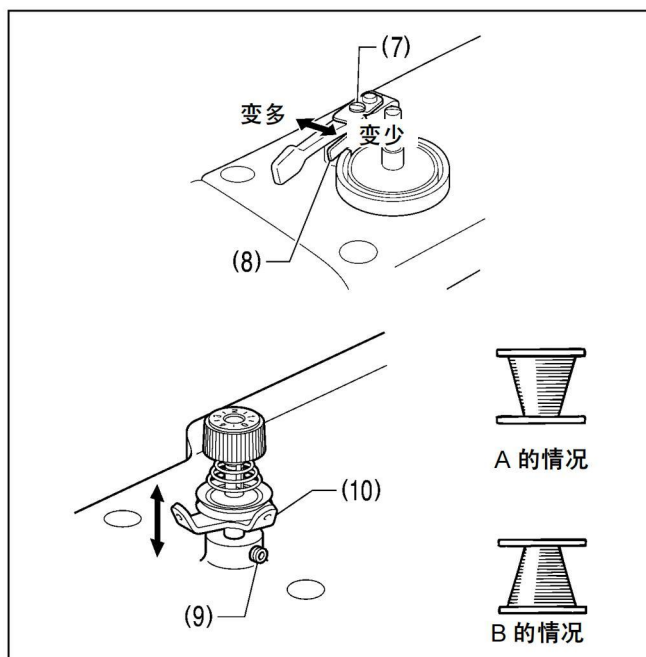

梭芯绕线量的调节

拧松螺钉(7)，移动梭芯压杆(8)进行调节。

绕线不均匀的调节

松开螺钉(9)，上下移动卷线器夹线组件(10)进行调节。

\* A的情况，将卷线器夹线组件(10)向下移动，B的情况，正好相反，向上移动。

### 5 - 5. 梭芯套的装取方法

#### ⚠ 注意



在安装梭芯套时，请切断电源。  
当误踩下脚踏开关时，缝纫机动作会导致人员受伤。

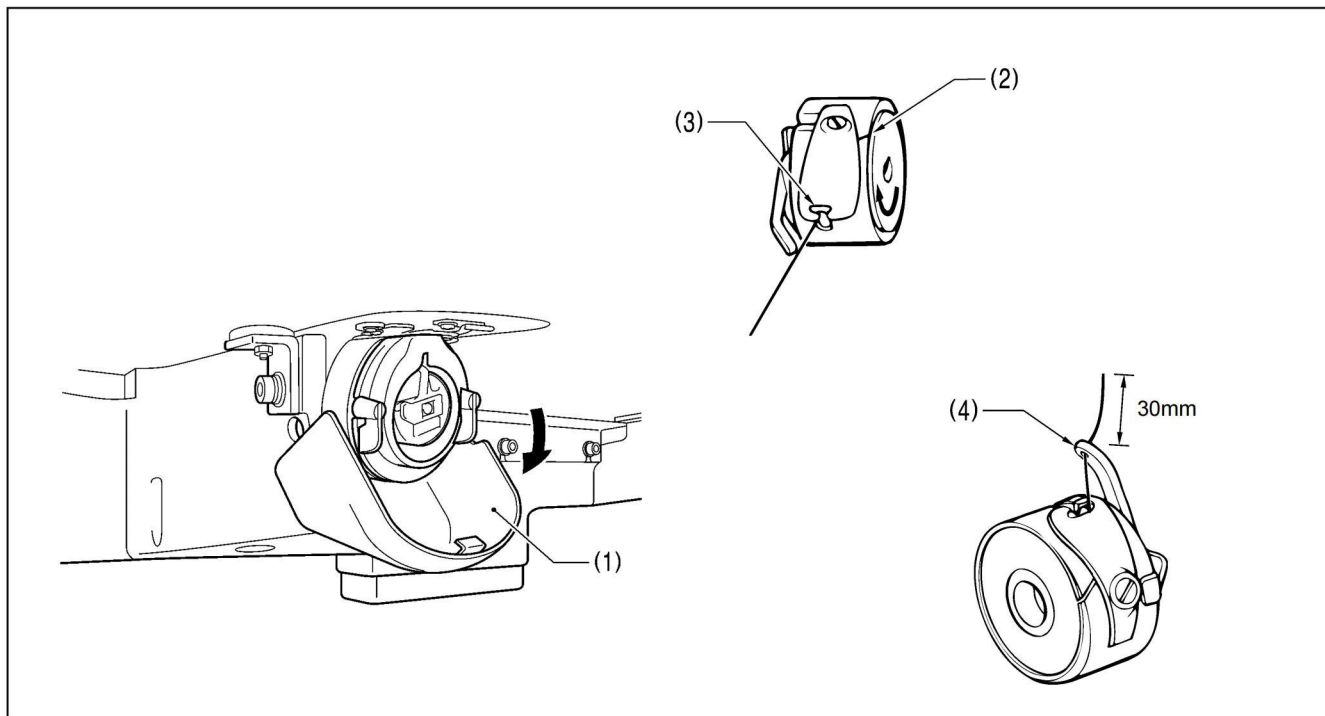

1. 向下拉大旋梭盖(1)将其打开。
2. 按底线向右卷绕的方向握住梭芯，然后将梭芯插入梭芯套。
3. 将底线穿过线槽(2)，然后从导线部(3)中拉出。
4. 当拉出底线后，检查梭芯是否按箭头方向转动。
5. 将线穿过套柄上的线孔(4)，使线端长出 30 mm 左右。
6. 拿住梭芯套上的捏手，将梭芯套插入旋梭。



## 5-6. 缝纫张力

### 参考线张力

|          |          |
|----------|----------|
| 面线       | 相当#20号   |
| 底线       | 相当#20号   |
| 面线的张力(N) | 1.4~1.8  |
| 底线的张力(N) | 0.3~0.4  |
| 预张力(N)   | 0.2~0.4  |
| 机针       | DP×17#19 |

### 5-6-1. 底线的张力

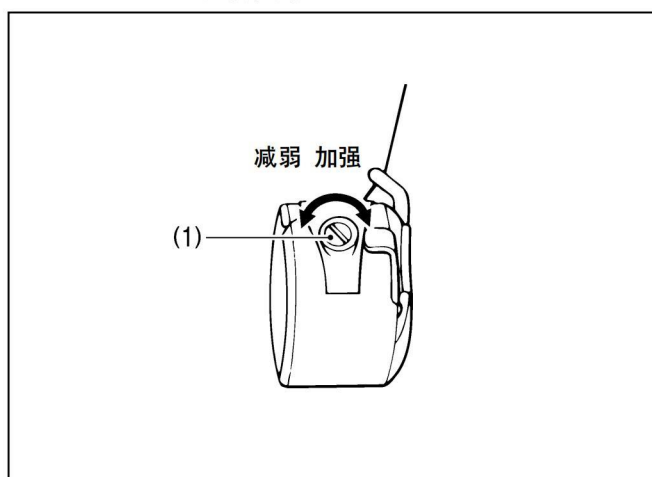

转动调节螺钉(1)来调节底线的张力，将张力调节到当用手握住线端时梭芯套靠它的自重不会滑落的程度，尽可能调弱张力。

### 5-6-2. 面线的张力

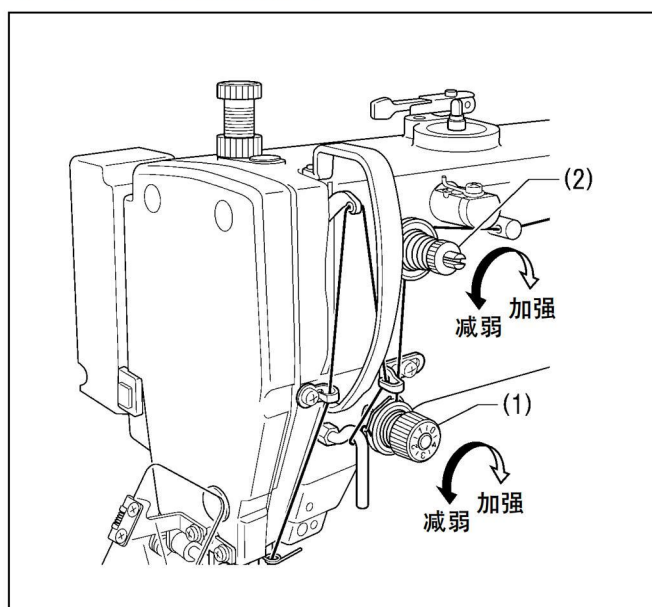

1. 转动夹线螺母(1)(主夹线器)，根据缝制品进行张力的调节。
2. 用夹线螺母(2)(副夹线器)进行调节，使面线残留在42mm左右的范围内。

## 6. 缝纫

### ⚠ 注意



发生下列情况时，请切断电源。  
当误踩脚开关时，缝纫机动作会导致受伤。

- 机针穿线时
- 更换机针或梭芯时
- 缝纫机不使用，或人离开缝纫机时



缝纫过程中不要触摸任何活动部件或将物件靠在运动部件上，因为这会导致受伤或缝纫机损坏。

### 6-1. 缝纫的方法

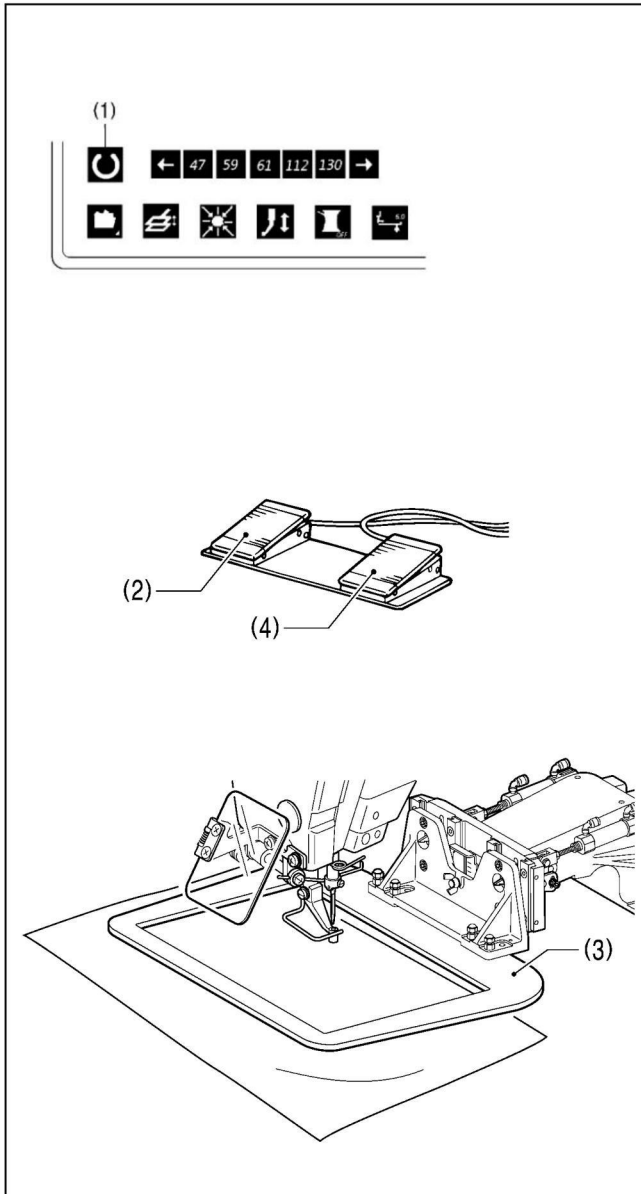

1. 打开电源。
2. 按 键或是 键，按数字键选择要缝纫的程序号。

3. 按回零键 (1) 进行原点检测。

4. 将布料放在压脚板 (3) 的下面
5. 踩下压脚开关 (2)。
  - 压脚板 (3) 下降。
6. 再踩下启动开关 (4)。
  - 缝纫机起动。

7. 缝纫一结束就剪线，然后压脚板 (3) 上升。

请使用能确保缝制布料不偏移的压脚板和送布板。

如使用标准的压脚板和送料板而缝制布料偏移时，请使用压脚板和送料板不能滑动的措施。

## 6-2. 暂停开关的使用方法

在缝制中或是试送布中，如果按了暂停开关(1)，缝纫机立即会停止。

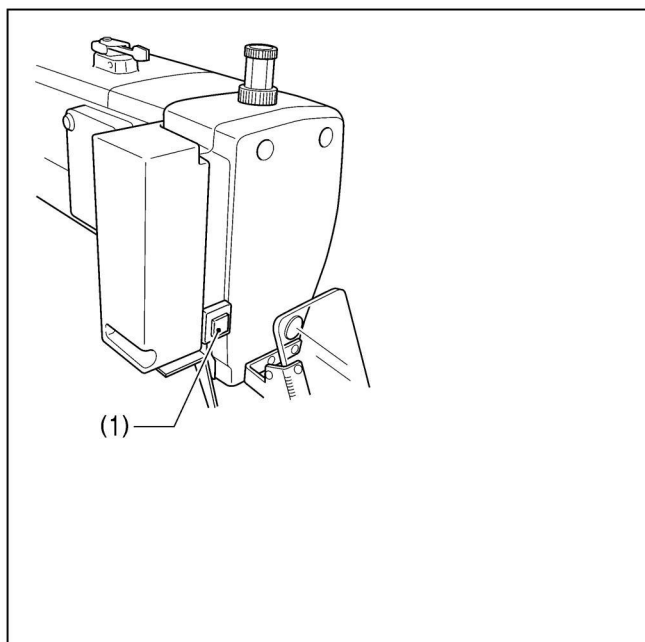

### <接着缝制的方法>

在缝纫中，当出现断线或是底线用完等情况时，按下了暂停开关(1)后，还是可以在出现断线的位置处继续接着缝制工作的。

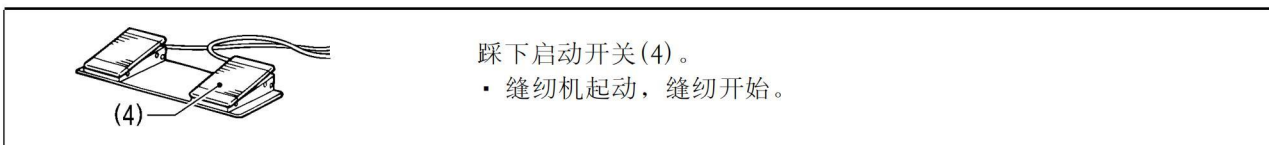

踩下启动开关(4)。  
 ▪ 缝纫机起动，缝纫开始。

## 6-3. 扫线用开关的使用方法

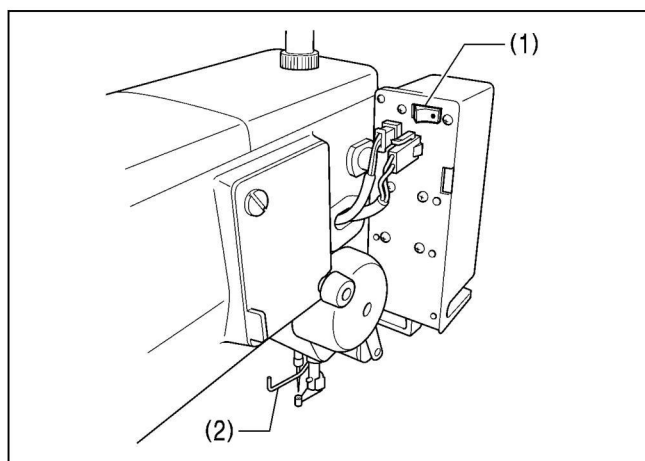

使用扫线用开关(1)，可以切换扫线杆(2)的开和关(ON, OFF)。

## 7. 保养

### ⚠ 注意



在开始清洁作业前，请切断电源。  
如果误踩了脚开关，缝纫机动作会导致人员受伤。



使用润滑油和黄油时，务必戴好保护眼镜和保护手套等，以防润滑油落入眼中或沾在皮肤上，这是引起发炎的原因。

另外，润滑油或黄油不能饮用，否则会引起呕吐和腹泻。  
将油放在儿童拿不到的地方。

### 7-1. 旋梭的清扫

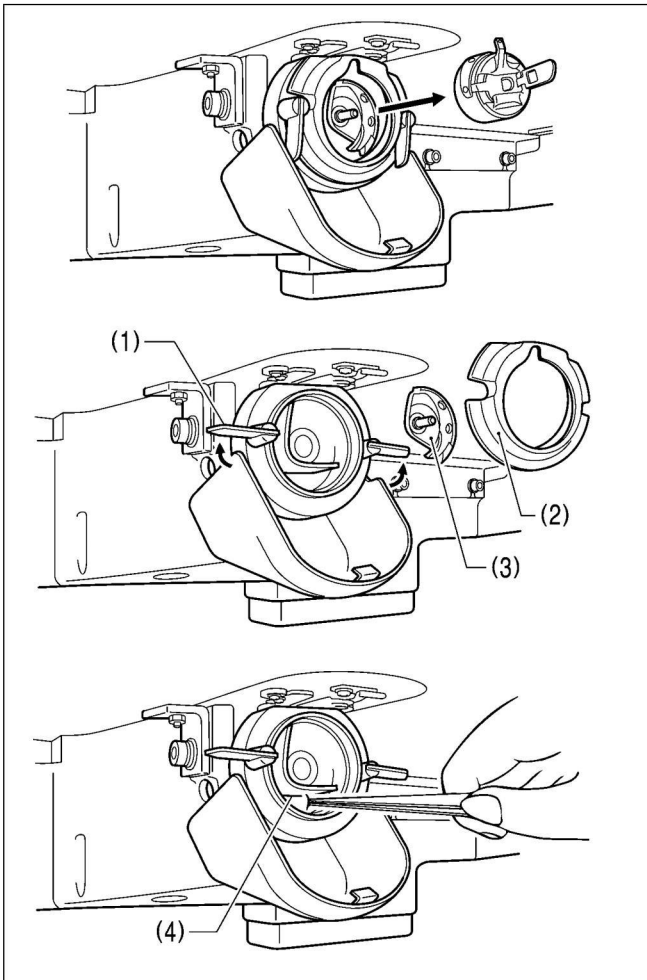

1. 将大旋梭盖向下拉开，取出梭芯盒。

2. 将大旋梭固定柄(1)朝箭头方向打开，取出大旋梭(2)和中旋梭(3)。

3. 将梭托(4)的四周，旋梭线导向上部及旋梭边缘的棉尘和线屑等清除干净。

### 7-2. 废油

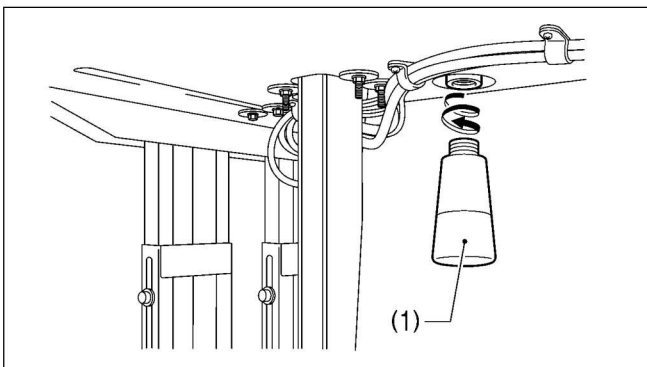

1. 当油壶(1)内积满了废油时，请拆下油壶(1)，并清除里面的废油。

2. 清除完后，将油壶(1)拧回到原来位置。

\*请遵守废油处理法规，正确处理废油。

### 7-3. 调节器的点检

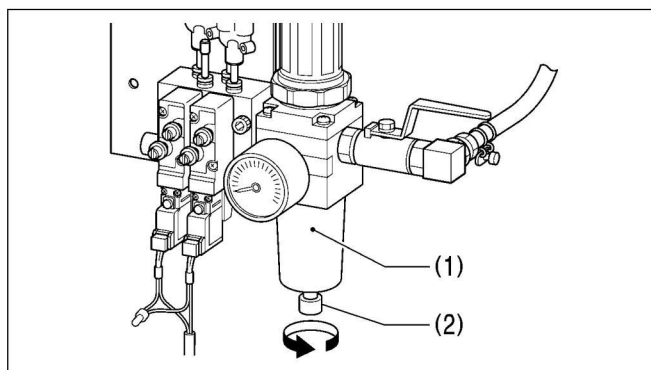

1. 在调节器(1)内的瓶中如有积水时, 排泄阀(2)按箭头方向回转来排泄积水。
2. 排泄完了后拧紧排泄阀(2)。

### 7-4. 控制箱进气口的清扫

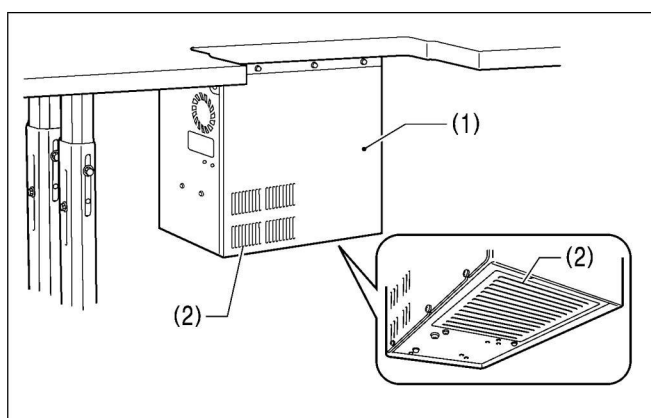

请每月一次左右用吸尘器清洁控制箱(1)的进气口(2)处的滤网。

### 7-5. 护眼板的清洁

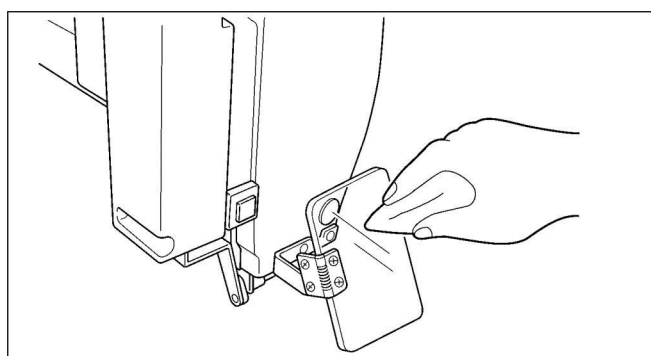

护眼板污秽时, 请用软布将其擦拭干净。

**[注意]**

请勿使用有机溶液如汽油或稀释剂清洁护眼板。

### 7-6. 机针的检查

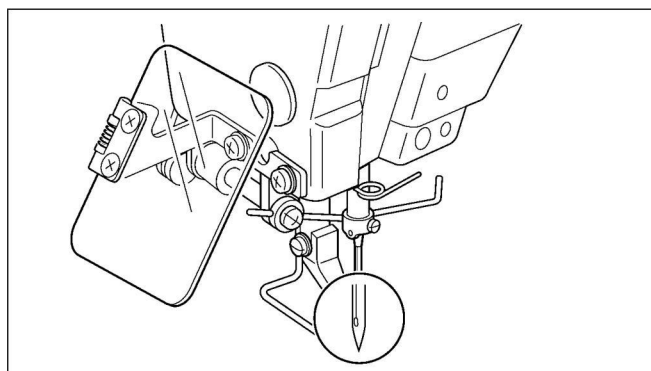

缝纫开始前先确认针头有否断裂, 机针有否弯曲。

### 7-7. 加油

参考「4-10. 加油」所述, 添加机油。

## 8. 标准调整

### ⚠ 注意

⊘ 只有经过训练的技术人员才能进行缝纫机的维修、保养和检查。

❗ 与电气有关的维修、保养和检查请委托购买商店或电气专业人员进行。

⚠ 发生下列情况时，请关闭电源。并拔下电源线插座。

否则误踩下脚踏开关时，缝纫机动作会导致受伤。

- 检查、调整和维修
- 更换旋梭等易损零部件

⚠ 在检查、调整和修理任何使用气动装备之前，请先断开气源，并等压力表指针下降到“0”为止。

⚠ 在必须接上电源开关和气源开关进行调整时，务必十分小心遵守所有的安全注意事项。

⚠ 缝纫机头倒下或竖起时，请用双手进行操作。另外在缝纫机头倒下的状态下，请不要用力压缝纫机。如缝纫机失去平衡，缝纫机头滑落到地上是造成受伤或缝纫机损坏的原因。

⊘ 使用润滑油及黄油时，务必戴好保护眼镜和保护手套等，以防润滑油及黄油落入眼中或沾在皮肤上，这是引起发炎的原因。

另外，润滑油及黄油不能饮用，否则会引起呕吐和腹泻。

将油放在儿童拿不到的地方。

❗ 取下的安全保护装置，必须要安装回去。且请务必安装在原位上，并检查能否正常的发挥作用。

### 8-1. 挑线簧的调整

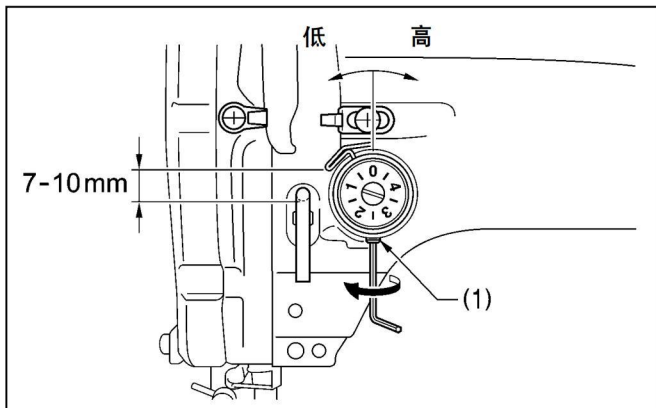

|           |         |
|-----------|---------|
| 挑线簧高度(mm) | 7~10    |
| 挑线簧强度(N)  | 0.6~1.2 |

#### <挑线簧高度>

松开固定螺钉(1)，转动调节器全体进行调整。

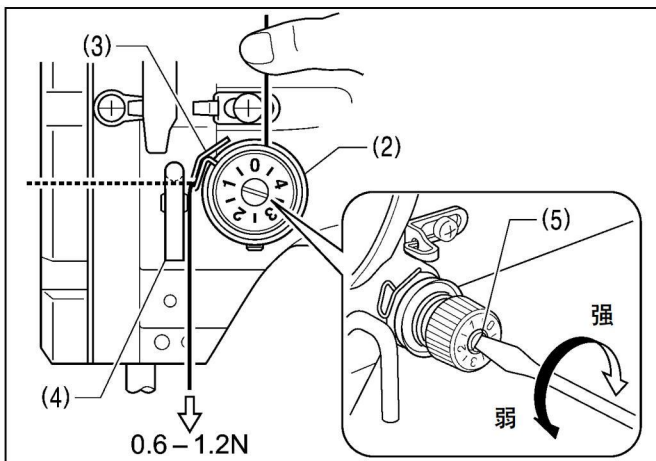

#### <挑线簧强度>

1. 在张力器基座(2)的稍稍上方，用手指压着面线使面线不能放出。
2. 将面线向下拉，使挑线簧(3)和机壳线钩(4)的底面呈一样高度的状态下，测试挑线簧(3)的强度。
3. 用螺丝刀转动夹线杆(5)进行挑线簧强度的调节。

#### [注意]

如果对挑线簧(3)不能正确地进行调整，那么每次剪线后，面线的残留量有可能会长短不一致。

## 8-2. 机壳线导向 R 的调整

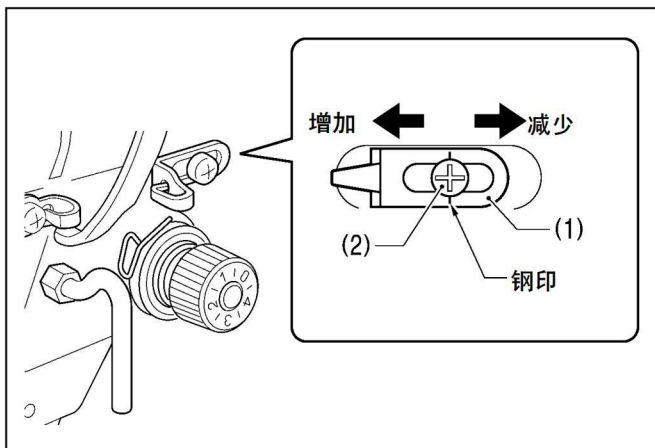

机壳线导向 R (1) 的位置，当螺钉 (2) 被固定在钢印的位置时为标准位置。

松开螺钉 (2)，移动机壳线导向 R (1) 进行位置的调节。

- 当缝纫厚料时，向左移动机壳线导向 R (1)。(挑线量增加。)
- 当缝纫薄料时，向右移动机壳线导向 R (1)。(挑线量减少。)

## 8-3. 针杆高度的调整

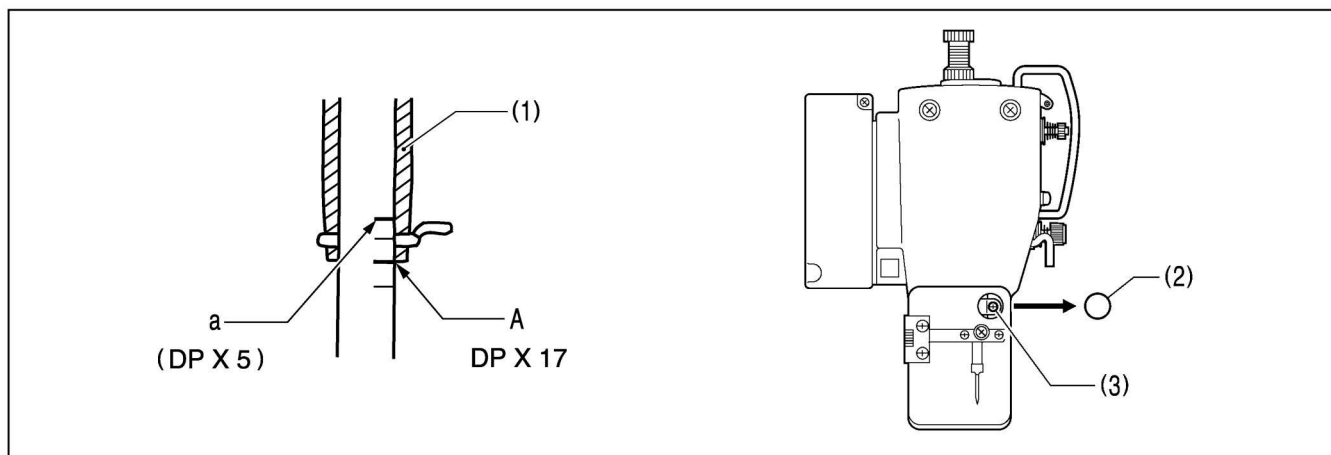

转动手轮使针杆降至最低点时，将针杆下方的第二根基线 A 与针杆轴套 (1) 下端对齐，卸下橡皮栓 (2) 并松开螺钉 (3)，上下移动针杆进行调整。

\*使用 DP × 5 的机针时，应与最上方的基线 a 对齐。

## 8-4. 针杆上升量的调整

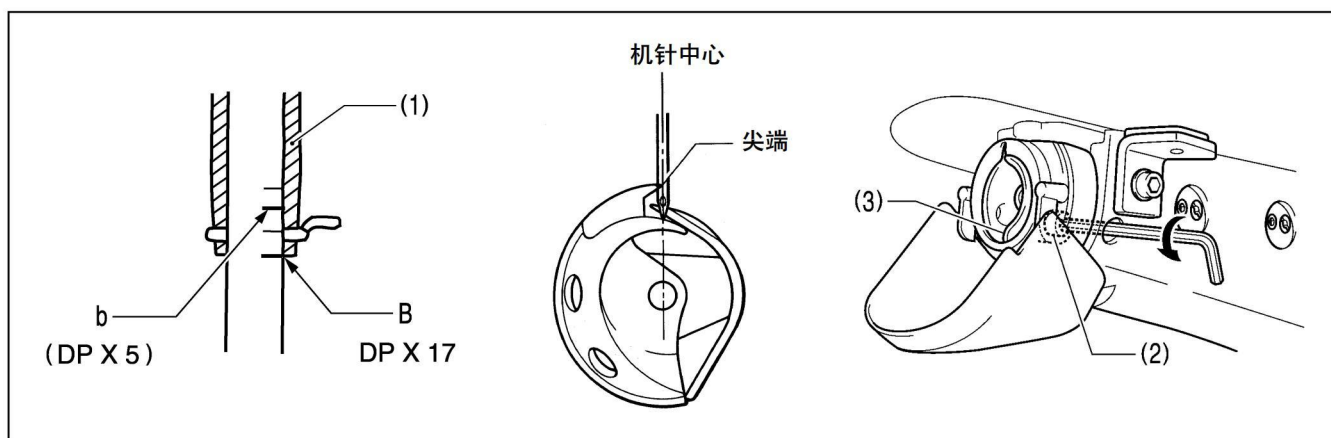

动手轮使针杆从最低点开始上升，当针杆最下方的基线 B 与针杆轴套 (1) 下端对齐时，旋梭尖端应与机针中心对齐一致，松开螺栓 (2)，移动梭托 (3) 进行调整。

\*使用 DP × 5 的机针时，应与从上方开始的第二根基线 b 对齐。

### 8-5. 梭托导针部的调整

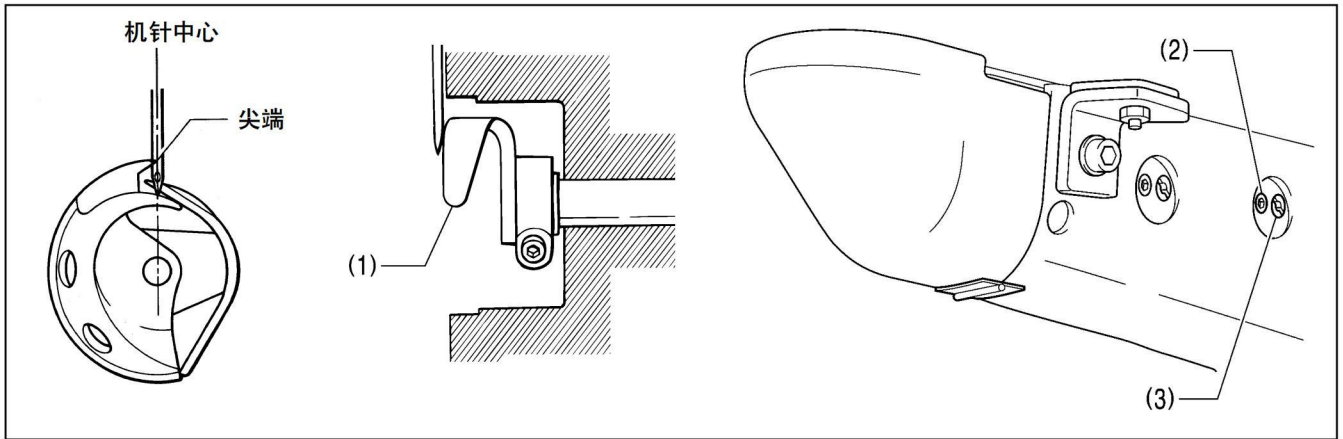

转动手轮使旋梭尖端与机针中心对齐时，梭托导针部(1)好象要与机针接触似的，松开螺钉(2)，转动旋梭调节轴(3)进行调整。

**[注意]**

如果导针部的过度导入会使机针的负担加重，还会引起夹线不良。此外，如果导针部不导入，则中旋梭的梭尖端会和机针相接触，会产生跳针的原因。

### 8-6. 针隙的调整

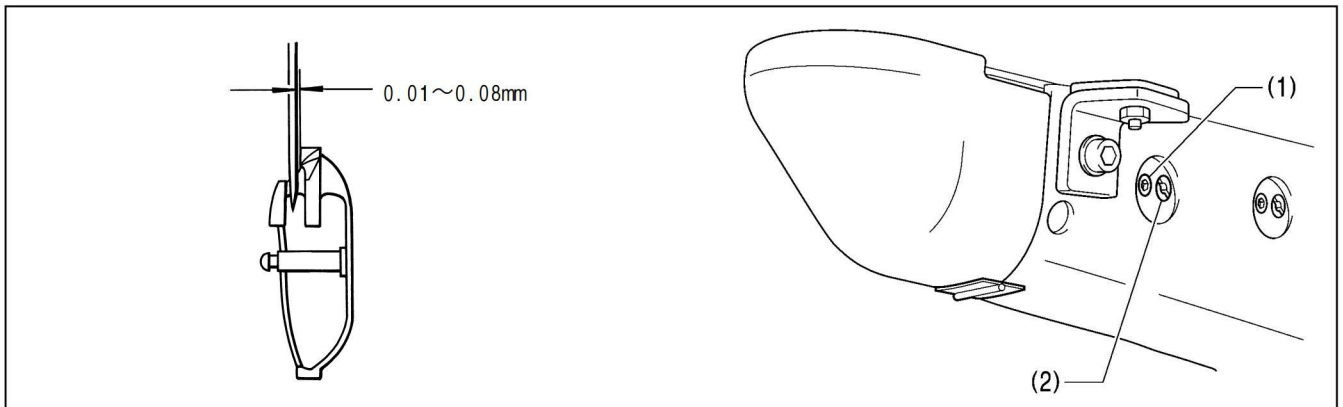

转动手轮使旋梭尖端与机针中心对齐时，机针和旋梭尖端之间的间距为0.01~0.08mm，并松开螺钉(1)，转动旋梭调节轴(2)进行调整。

### 8-7. 旋梭导线器的调整

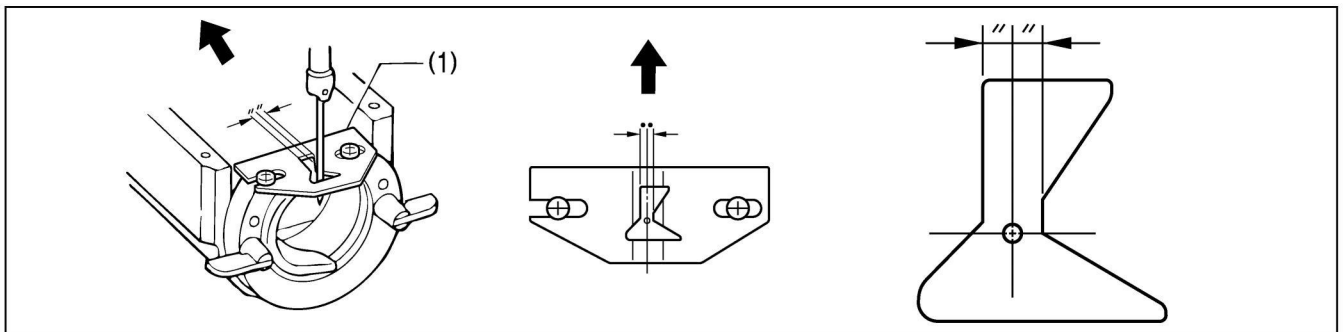

左右位置是将旋梭导线器(1)的针槽作为机针中心的分配位置，前后位置是将旋梭导线器(1)按箭头方向压上并安装的位置。

**[注意]**

如果旋梭导线器(1)的位置不佳，则会导致断线，缝线受污或是线被缠绕。

旋梭导线器的位置(1)在出厂时已作调整完。请尽可能不作改动。



## 8-8. 旋梭供油量的调整

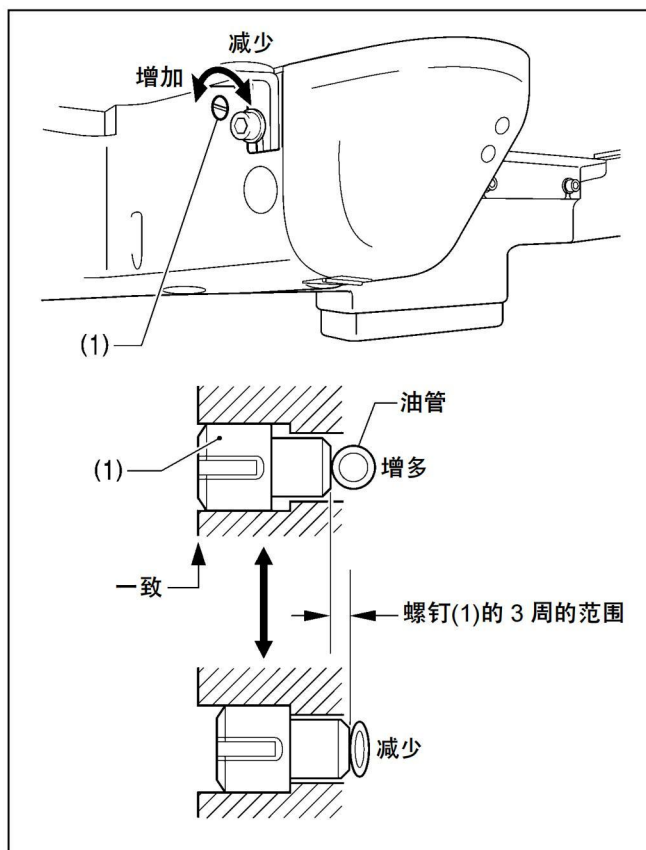

## &lt;根据油管的压入量进行调整&gt;

螺钉(1)的头部和底板的端面呈一致状态时为适量的位置。供油量的调节,可从该位置起向右旋转3周的范围内进行调节。

- 螺钉(1)向右旋转时供油量减少。
- 螺钉(1)向左旋转时供油量增加。

\* 如果想要比螺钉(1)的头部和底板的端面呈一致状态时更多的供油时,请使用下述方法进行调整。

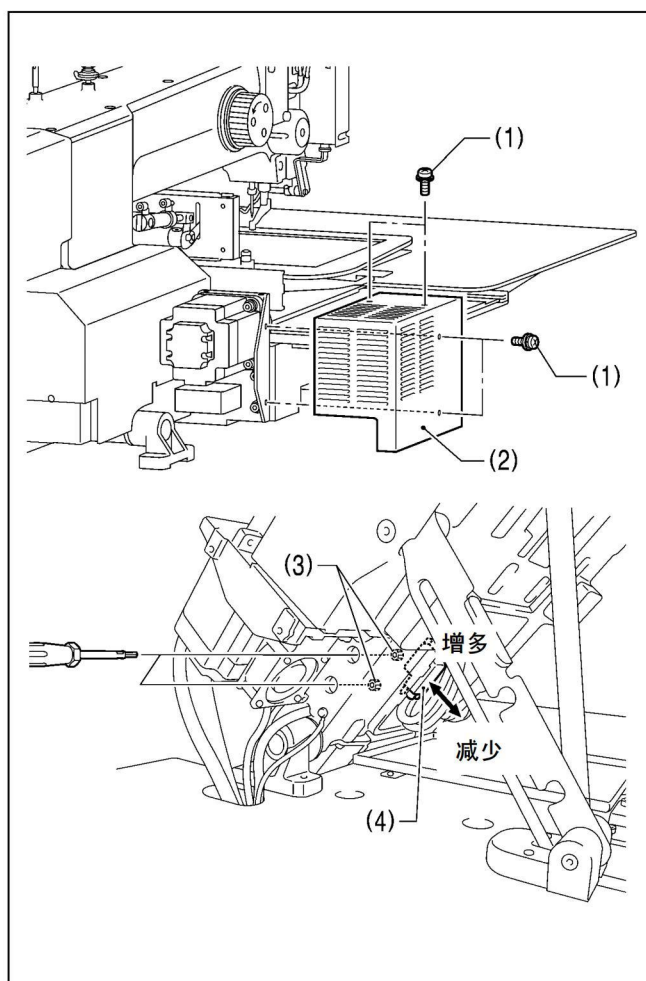

## &lt;调整副油罐的供油量&gt;

1. 旋下螺钉(1)[4个],取出X马达罩(2)。

2. 将缝纫机头倒下。
3. 从缝纫机机壳的左侧面的孔中用起子将螺栓(3)[2个]松开。
4. 上下移动副油罐(4)进行位置调整后,拧紧螺栓(3)[2个]。
  - 副油罐(4)的位置向上移动,供油量增加。
  - 副油罐(4)的位置向下移动,供油量减少。
5. 将缝纫机头竖起。
6. 使用螺钉(1)[4个],将X马达罩(2)安装上。

### 8-9. 动刀的位置调整

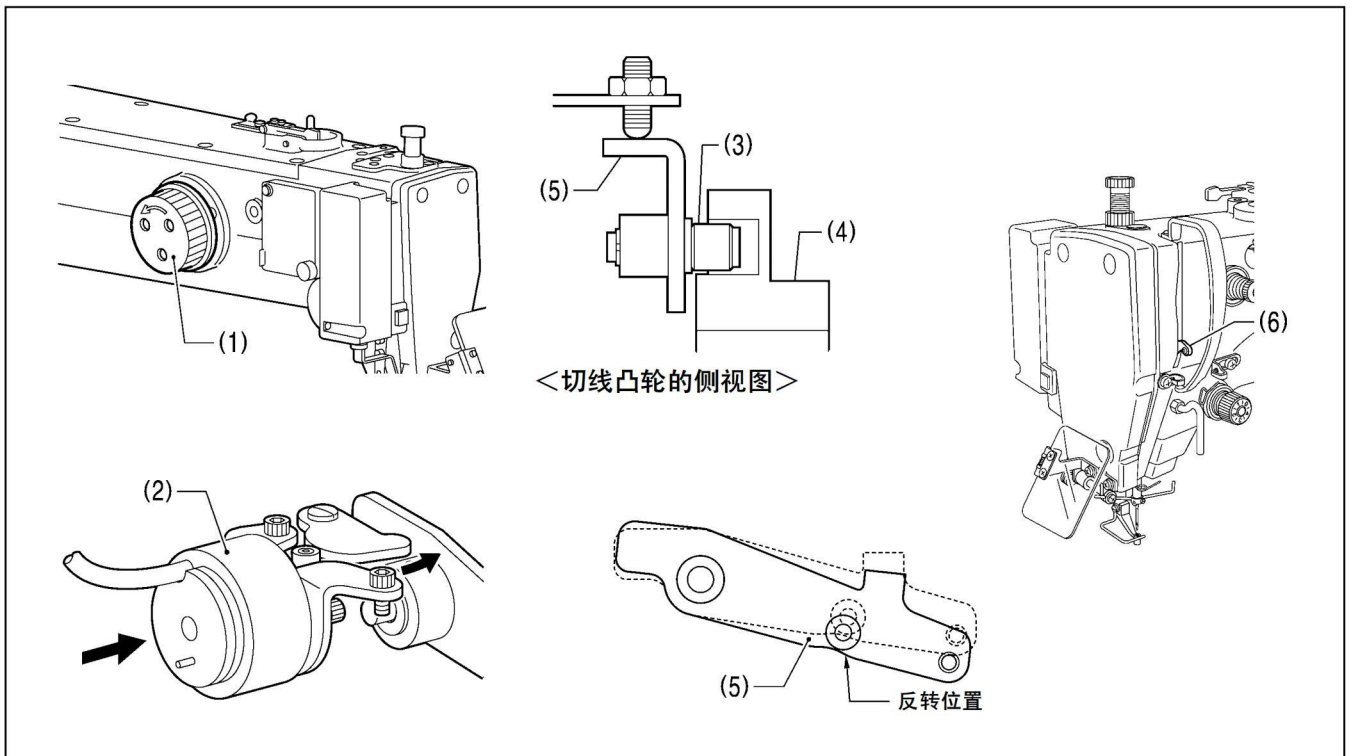

1. 取下上盖，将机头放倒。
2. 用手转动手轮(1)使针杆在最低位置后，将切线电磁铁(2)完全压到底。
3. 在切线滚轮(3)嵌入切线凸轮(4)的槽中的状态下，用手回转手轮(1)，使切线驱动杆(5)在反转位置(挑线杆(6)处于最低位置附近)。

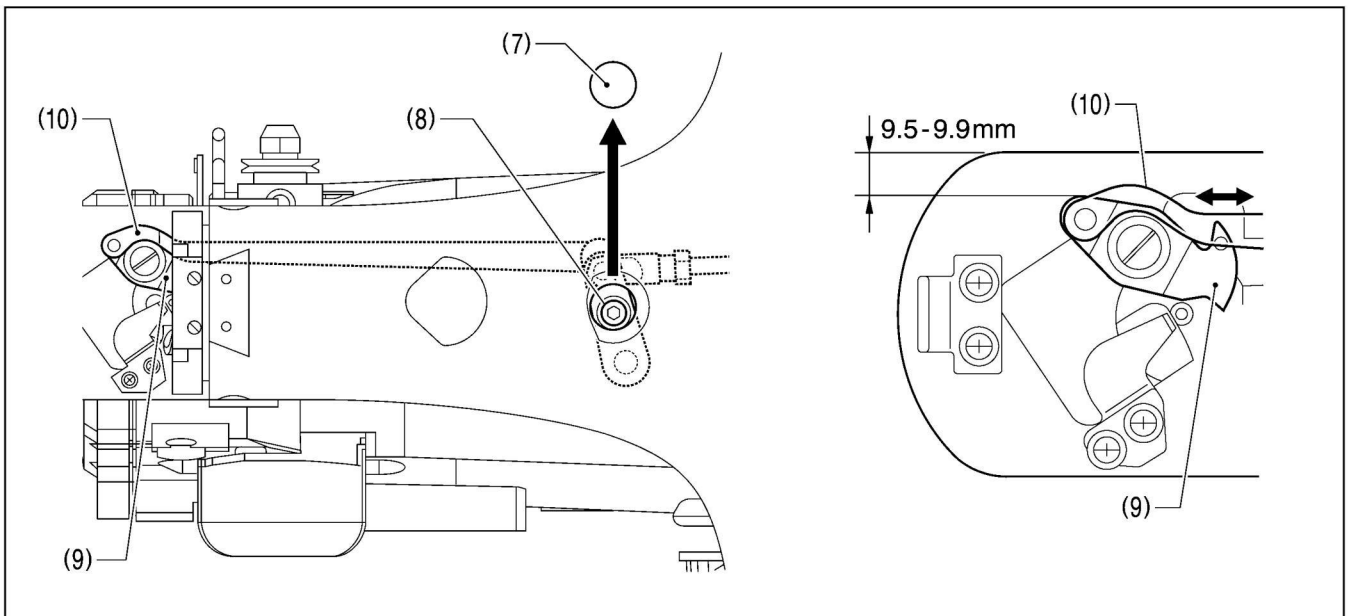

4. 取下橡皮塞(7)。
5. 松开螺栓(8)。
6. 将针板右侧的棱线到动刀(9)的棱线之间的距离保持在 9.5~9.9 mm，前后移动动刀连杆(10)来进行调整。
7. 拧紧螺栓(8)后，再次确认上述的位置。

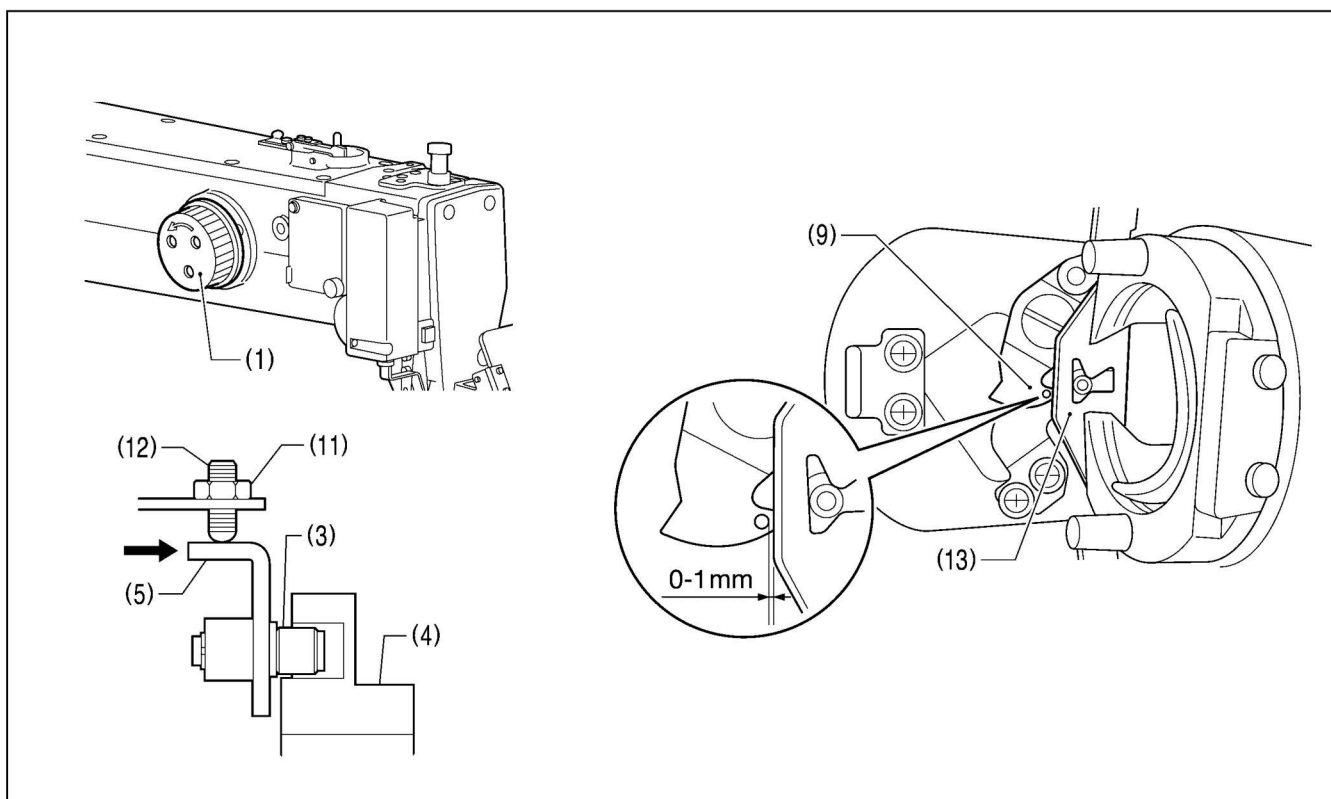

8. 用手转动手轮(1)使针杆置于最低位置。
9. 松开螺母(11)，将嵌入切线凸轮(4)槽中的切线滚轮(3)在碰到其内侧为止后旋紧螺钉(12)，再从此开始将其按逆时针方向回转约1/4转。
10. 旋紧螺母(11)，确认切线滚轮(3)不能接触到切线凸轮(4)的内侧。还有，用手将切线驱动杆(5)推向切线凸轮侧，切线滚轮(3)嵌入到切线凸轮(4)的槽中后，当松开手后确认切线驱动杆(5)应能顺畅地复位。
11. 动刀(9)的孔的外周和旋梭线导向(13)的棱线，在没有空隙的状态下确认其范围在0~1mm之间。

## 8-10. 动刀和定刀的更换方法

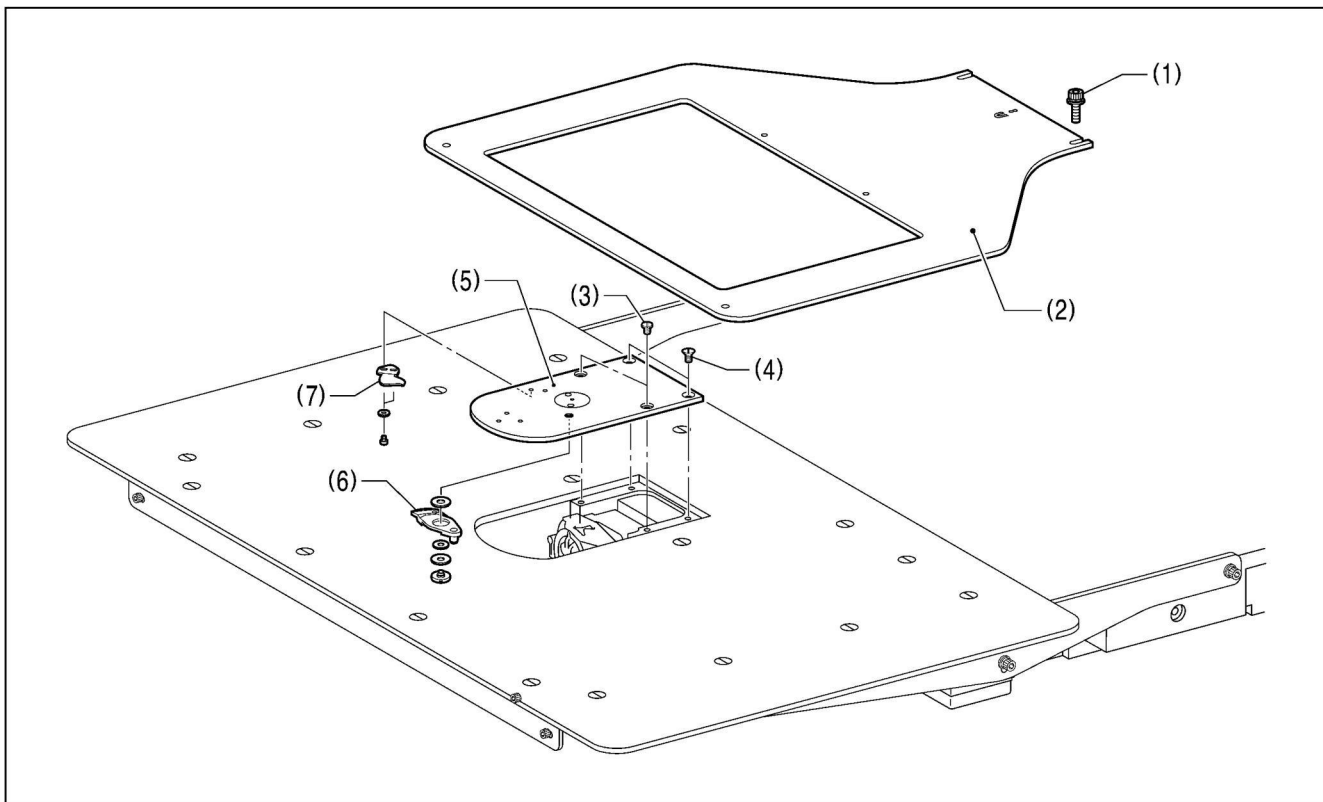

1. 松开螺栓(1) [2个]，拆下送料板(2)。
2. 打开大旋梭盖，旋下螺钉(3)[2个]和螺钉(4)[2个]，拆下针板(5)。
3. 拆下动刀(6)和定刀(7)。

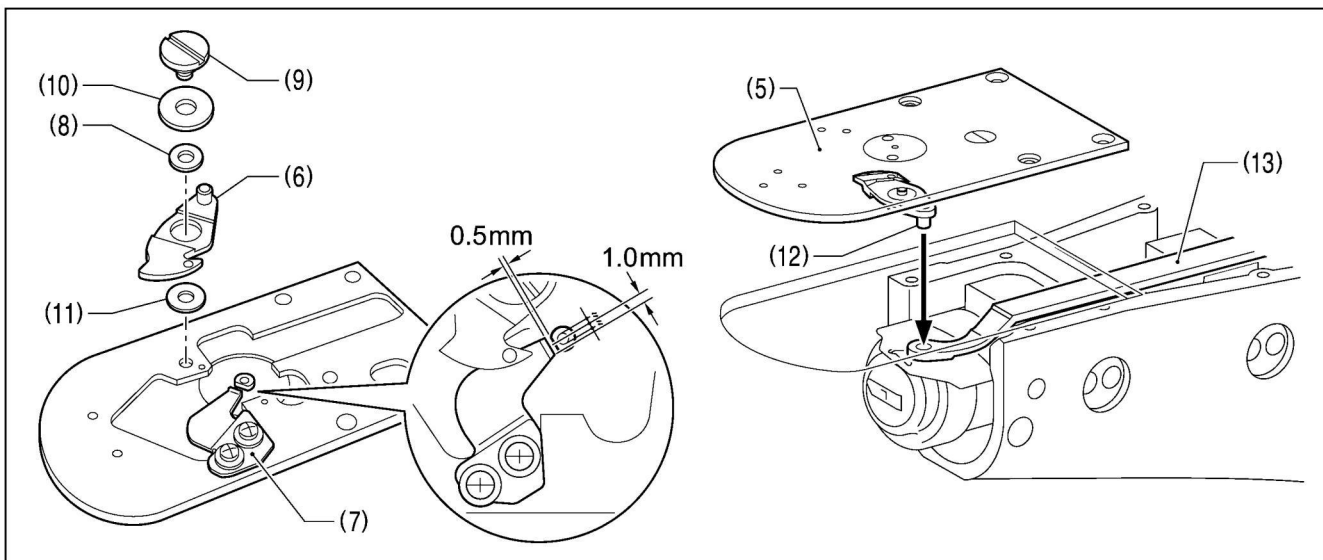

4. 在如图所示位置安装新的定刀(7)。
5. 在动刀圈套(8)的外周部和段螺钉(9)处涂上润滑脂,和轴向垫圈(10)及动刀之间的垫片(11),再加上新的动刀(6)一起安装。
6. 确认动刀(6)和定刀(7)在切线时的锋利度。为了能很好的切线使用附属的动刀之间的垫片(厚度  $t=0.2、0.3、0.4$ ) 来进行调整。  
\*当刃压很低,不能完全切断缝线时,请使用薄的动刀之间的垫片。  
\*当刃压很高,动刀(1)的回转很重时,请使用厚的动刀之间的垫片。
7. 在动刀的销(12)处涂上润滑脂嵌入动刀连杆(13)的孔中,然后安装针板(5)。
8. 确认针孔中心和机针对齐。
9. 安装上送料板(2)。(参考下一页)

## 8-11. 扫线器的调整

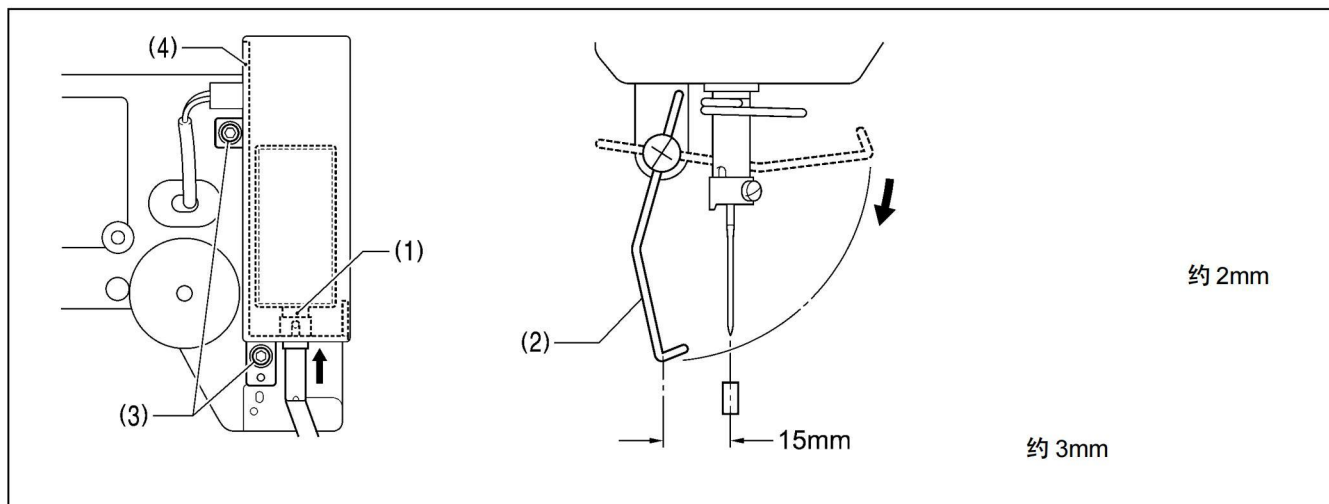

1. 扫线器的电磁铁插棒(1)被拉到最大时, 为使扫线杆(2)能扫过机针中心向前 15mm 处, 将螺钉(3) [2 个] 松开, 电磁铁安装板(4)整体上下移动来进行调整。
2. 操作扫线杆(2)为了使其在通过机针的下面时, 扫线杆(2)和机针的尖端之间的间隙约为 2mm 左右, 扫线杆(2)的尖端到机针中心约为 3mm 左右, 松开螺钉(5)调整扫线杆(2)的位置。

**[注意]**

请确认扫线杆(2)不可碰到护指器(6)。

### 8-1 2. 间歇压脚的安装位置

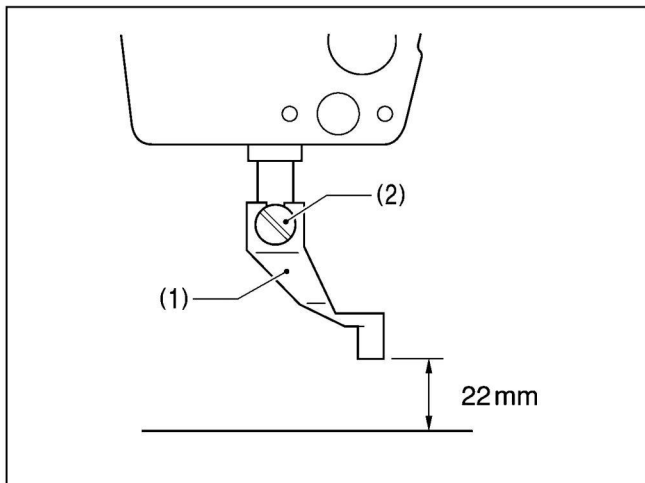

缝纫机在停止位置处间歇压脚(1)呈上升状态时,从间歇压脚(1)的底部到针板表面的距离为 22mm 时将螺钉(2)装上拧紧。

### 8-1 3. 间歇压脚行程的变换

根据间歇压脚连杆的位置调整、及间歇连杆 A 的安装位置的更改,可以在 2~10mm 之间更改间歇压脚的行程。

#### <间歇连杆 A 的安装位置的更改>

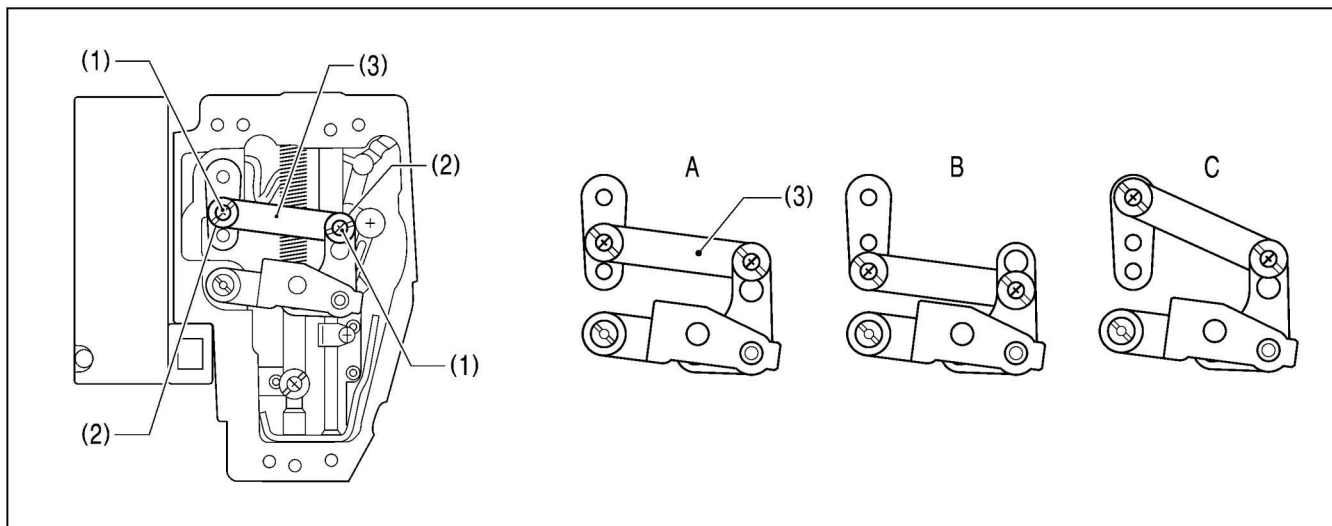

1. 拆下面板。
2. 取出螺钉(1) [2 个] 和段螺钉(2) [2 个], 拆下间歇连杆 A(3)。
3. 间歇连杆 A(3) 的安装位置可更改成在上述的 A~C 中的任何位置。

在各个不同的安装位置处,如下表所示,当对间歇连杆的位置进行调整时,间歇压脚的行程在下表所示的范围内可进行调整。(参考下一页)

| 安装位置 | 间歇压脚行程的范围        |  |
|------|------------------|--|
| A    | 2~4.5mm          |  |
| B    | 4.5~10mm         |  |
| C    | 0mm (间歇压脚不能上下移动) |  |

## &lt;间歇压脚连杆的位置调整&gt;

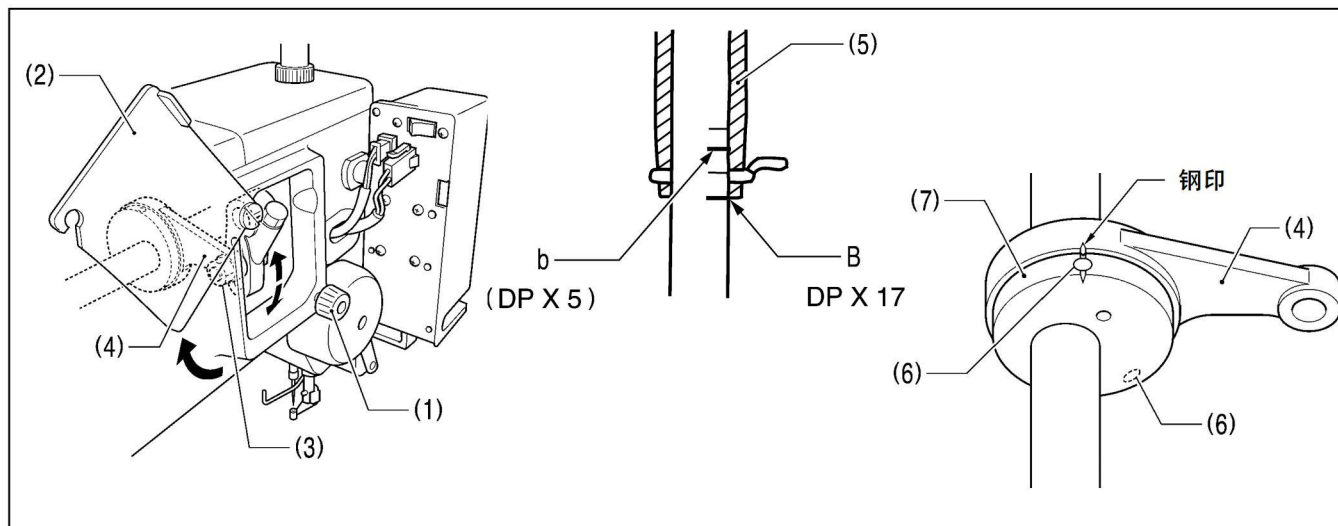

1. 松开螺钉(1)，打开间歇盖板(2)。
2. 旋松螺母(3)，调整间歇压脚连杆(4)的位置。
  - 如将间歇压脚连杆(4)向上去的位置时，间歇压脚行程变大。
  - 如将间歇压脚连杆(4)向下去的位置时，间歇压脚行程变小。

下面是针杆和间歇压脚操作时应同步。

3. 回转手轮让针杆从最下点向上升，使针杆的最下面的基线和针杆轴套(5)的下端面一致对齐。(如果是使用 DP × 5 的机针时，请与从上往下数第二条的基线 b 一致对齐。)
4. 拆下上盖，旋松螺钉(6) [2 个]。
5. 使间歇压脚凸轮(7)和间歇压脚连杆(4)的钢印一致后，拧紧螺钉(6)。

间歇压脚的行程变更之后，请进行以下的确认。

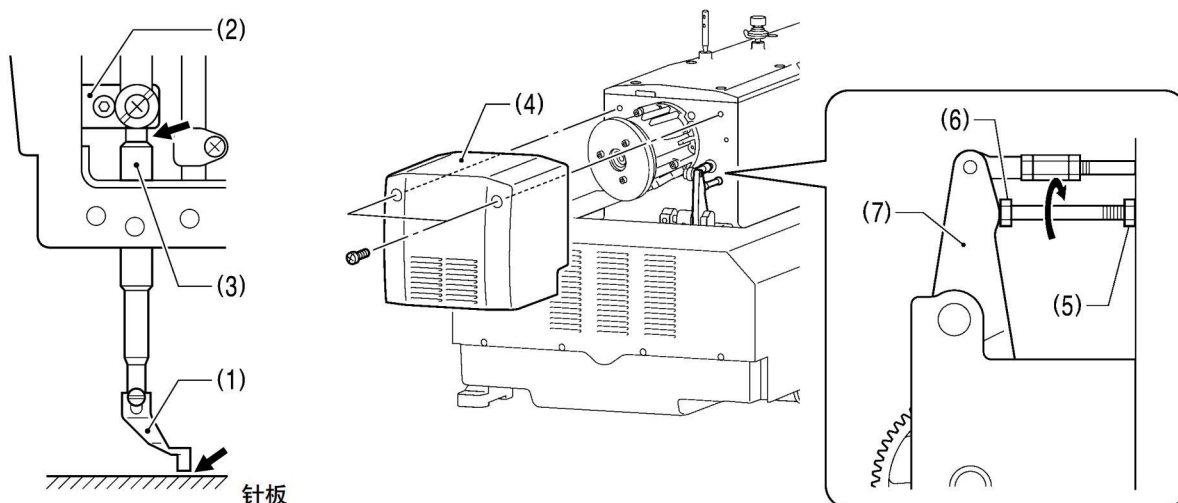

1. 在间歇压脚(1)呈下降状态，回转手轮使间歇压脚(1)降到最下点。
2. 确认间歇压脚(1)是否没碰到针板，还有压杆抱箍(2)是否也没碰到压杆轴套(3)。

## &lt;如果有碰到时&gt;

拆下马达盖(4)。

旋松螺母(5)，回转螺栓(6)使其推动间歇驱动杆(7)来调整，直到上述 2 处不被碰到为止。

### 8-14. 压脚上升量的调整

压脚板(2)的最大上升量为从针板向上 30mm。

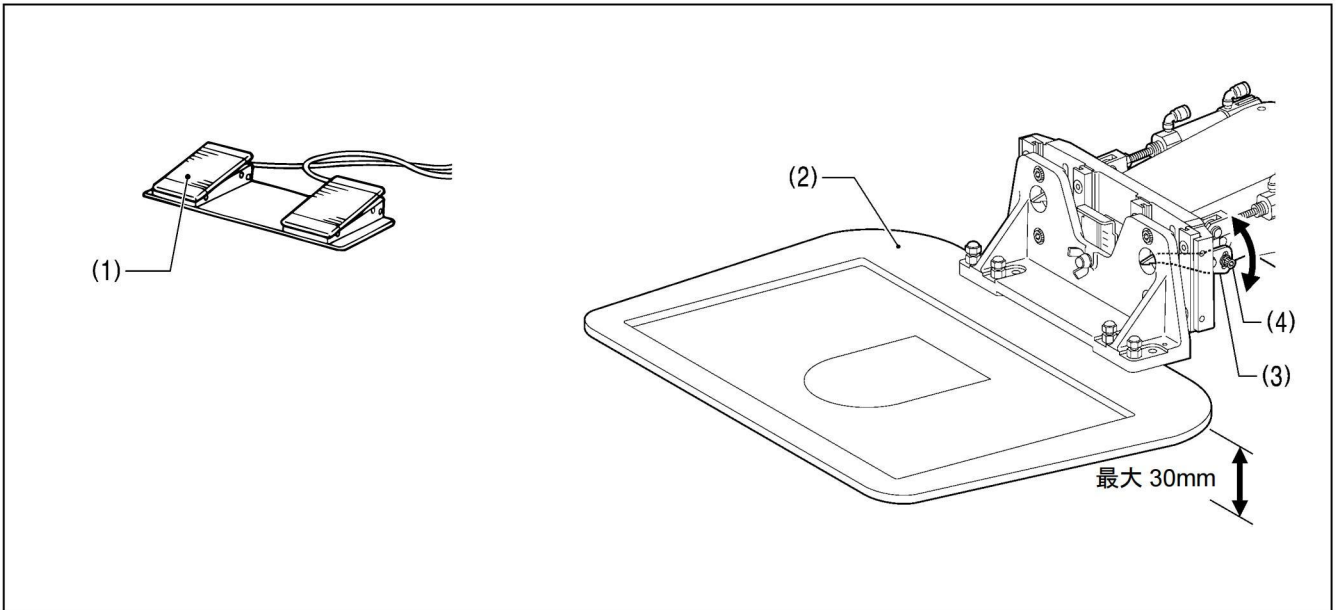

1. 送入气压，接通电源开关。
2. 踩下压脚开关(1)，压脚板(2)上升。
3. 旋松压脚臂杆(3)的螺栓(4) [2个]，上下移动压脚臂杆(3)来进行调整。

### 8-15. 空气压力的调整

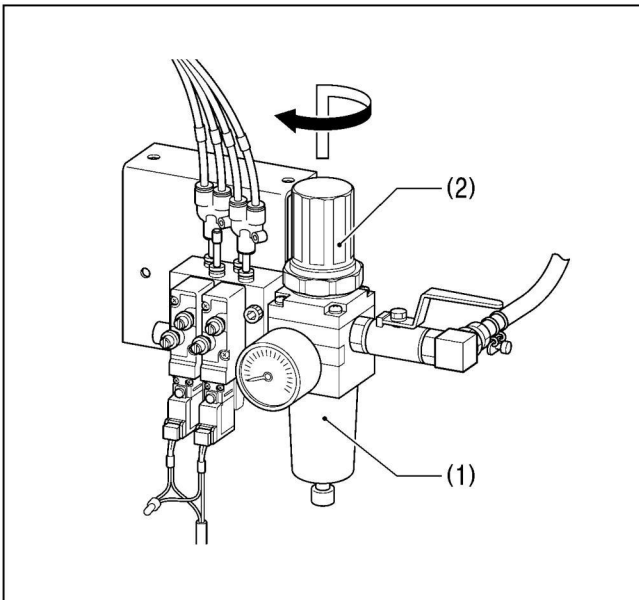

将调节器(1)的手轮(2)向上拔起后再回转，使空气压力调整到 0.5MPa。

调整完了后，按下手轮(2)并锁住。



## 9. 故障检修

- 请您在要求维修或服务前，先检查以下各项。
- 如果以下方法仍然不能解决问题，关闭电源开关，向受过训练的技术人员或经销商咨询。

### 注意



在作业之前，请先关闭电源开关。并将电源插头从插座上拔下。  
如果误踩脚踏开关，缝纫机动作会导致受伤。

| 现象                 | 原因               | 措施                  | 参照    |
|--------------------|------------------|---------------------|-------|
| 压脚板不能上升<br>压脚板不能下降 | 压脚动作很重           | 在压脚滑块的运动部分涂敷适当的润滑脂  |       |
|                    | 抬压脚汽缸的空气接管的弯曲，破损 | 修正弯曲了的空气接管或更换新的空气接管 |       |
| 压脚上升量不正确           | 压脚臂杆的位置不对        | 调整压脚臂杆的位置           | P. 33 |
| 压脚板不能上升到最高点        | 压脚汽缸接头的位置不对      | 调整压脚汽缸接头的位置         |       |
| 扫线器动作不好            | 扫线器和机针有干扰        | 调整扫线器的高度            | P. 30 |
|                    |                  | 调整扫线器的运动量           | P. 30 |
|                    | 扫线器的位置不对         | 调整扫线器的运动量           | P. 30 |
| 底线绕线时被卷在一边         | 卷线夹线器组的高度不对      | 调整卷线夹线器组的高度         | P. 16 |
| 底线被卷的线量不恰当         | 梭芯压杆的位置不对        | 调整梭芯压杆的位置           | P. 16 |
| 脱线                 | 在缝纫开始时有脱线        | 请参考「跳针」一览           | P. 35 |
|                    | 面线的残余量不稳定，偏差很大   | 调整副夹线器              | P. 18 |
|                    | 旋梭导线器的位置不对       | 调整旋梭导线器的位置          | P. 25 |

| 现象   | 原因                    | 措施                   | 参照    |
|------|-----------------------|----------------------|-------|
| 面线断线 | 面线张力太强                | 调整面线张力               | P. 18 |
|      | 机针的安装方法不正确            | 正确的方向安装机针            | P. 13 |
|      | 和机针相比线太粗              | 选择使用符合机针的线           | P. 18 |
|      | 挑线簧的强度和高度不正确          | 调整挑线簧的强度和高度          | P. 23 |
|      | 旋梭, 针孔板和机针等有碰伤, 划伤和毛刺 | 分别将这些零部件的伤痕和毛刺研磨或更换  |       |
|      | 因发热断线(化纤线)            | 使用冷却液槽               | P. 14 |
|      | 穿线不正确                 | 在线道上正确穿线             | P. 14 |
| 底线断线 | 底线张力太强                | 调整底线张力               | P. 18 |
|      | 针孔板, 和梭芯盒的角部有碰伤, 划伤   | 分别将这些零部件的伤痕研磨或更换     |       |
| 跳针   | 机针和旋梭尖端的间隙过大          | 调整机针的间隙              | P. 25 |
|      | 机针和旋梭的相遇不正确           | 调整针杆的上升量             | P. 24 |
|      | 梭托过度的(必要以上)导入了机针      | 调整梭托导针部              | P. 25 |
|      | 机针弯曲                  | 更换机针                 |       |
|      | 机针的安装方法不正确            | 正确的方向安装机针            | P. 13 |
| 断针   | 机针和旋梭尖端的间隙过大          | 调整机针的间隙              | P. 25 |
|      |                       | 调整针杆的上升量             | P. 24 |
|      | 机针弯曲                  | 更换机针                 |       |
|      | 进针时机针被拉偏              | 选择符合缝纫条件的机针<br>降低回转数 | P. 18 |
|      | 机针太细                  | 选择符合缝纫条件的机针          | P. 18 |
| 咬线   | 挑线簧的强度和高度不正确          | 调整挑线簧的强度和高度          | P. 23 |
|      | 机针和旋梭的相遇不正确           | 调整针杆的上升量             | P. 24 |
|      | 旋梭导线器没能分线             | 调整旋梭导线器的位置           | P. 25 |

| 现象                    | 原因               | 措施                    | 参照    |
|-----------------------|------------------|-----------------------|-------|
| 面线未切断                 | 动刀的刀锋不利          | 更换新的动刀                | P. 29 |
|                       | 定刀的刀锋不利          | 磨快定刀或是更换新的定刀          | P. 29 |
|                       | 动刀勾不住面线          | 调整旋梭导线器的位置            | P. 25 |
|                       |                  | 调整针杆的上升量              | P. 24 |
|                       | 最后一针因跳针, 动刀勾不住面线 | 请参考「跳针」一览             | P. 35 |
|                       | 动刀的位置不正确         | 调整动刀的位置               | P. 27 |
| 副夹线器的张力太弱             | 回转夹线螺母进行调整       | P. 18                 |       |
| 布料的背面缝纫针迹不良           | 旋梭导线器不能完全分线      | 调整旋梭导线器的位置            | P. 25 |
|                       | 面线不够紧密           | 调整面线张力                | P. 18 |
|                       | 面线的残余量不稳定, 偏差很大  | 调整副夹线器                | P. 18 |
| 线不够紧密                 | 面线张力太弱           | 调整面线张力                | P. 18 |
|                       | 底线张力太弱           | 调整底线张力                | P. 18 |
|                       | 挑线簧的强度和高度不正确     | 调整挑线簧的强度和高度           | P. 23 |
|                       | 机壳线导向 R 的位置不正确   | 调整机壳线导向 R 的位置         | P. 24 |
| 面线的残余量不稳定, 偏差很大       | 挑线簧的强度和高度不正确     | 调整挑线簧的强度和高度           | P. 23 |
|                       | 副夹线器的张力太弱        | 回转夹线螺母进行调整            | P. 18 |
|                       | 定刀的刀锋不利          | 磨快定刀或是更换新的定刀          | P. 29 |
| 接通电源, 即使踩下脚踏开关缝纫机也不启动 | 安全开关不起作用         | 确认安全开关的电源线是否脱开着       | /     |
|                       |                  | 调整安全开关的位置             | P. 12 |
|                       |                  | 如果安全开关有故障的话<br>更换新的开关 | /     |

Thank you very much for buying a sewing machine from my company. Before using your new machine, please read the safety instructions below and the explanations given in the instruction manual.

With industrial sewing machines, it is normal to carry out work while positioned directly in front of moving parts such as the needle and thread take-up lever, and consequently there is always a danger of injury that can be caused by these parts. Follow the instructions from training personnel and instructors regarding safe and correct operation before operating the machine so that you will know how to use it correctly.



## SAFETY INSTRUCTIONS

### [1] Safety indications and their meanings

This instruction manual and the indications and symbols that are used on the machine itself are provided in order to ensure safe operation of this machine and to prevent accidents and injury to yourself or other people.

The meanings of these indications and symbols are given below.

#### Indications

|  |  |
|--|--|
|  <b>DANGER</b>  | The instructions which follow this term indicate situations where failure to follow the instructions will result in death or serious injury.   |
|  <b>CAUTION</b> | The instructions which follow this term indicate situations where failure to follow the instructions could cause injury when using the machine or physical damage to equipment and surroundings. |

#### Symbols



..... This symbol (  ) indicates something that you should be careful of. The picture inside the triangle indicates the nature of the caution that must be taken.  
(For example, the symbol at left means “beware of injury”.)



..... This symbol (  ) indicates something that you must not do.



..... This symbol (  ) indicates something that you must do. The picture inside the circle indicates the nature of the thing that must be done.  
(For example, the symbol at left means “you must make the ground connection”.)

## [2] Notes on safety







### DANGER













Wait at least 5 minutes after turning off the power switch and disconnecting the power cord from the wall outlet before opening the cover of the control box. Touching areas where high voltages are present can result in severe injury.

### CAUTION

#### Environmental requirements









-  Use the sewing machine in an area which is free from sources of strong electrical noise such as electrical line noise or static electric noise. Sources of strong electrical noise may cause problems with correct operation.
-  Any fluctuations in the power supply voltage should be within  $\pm 10\%$  of the rated voltage for the machine. Voltage fluctuations which are greater than this may cause problems with correct operation.
-  The power supply capacity should be greater than the requirements for the sewing machine's power consumption. Insufficient power supply capacity may cause problems with correct operation.
-  The pneumatic delivery capability should be greater than the requirements for the sewing machine's total air consumption. Insufficient pneumatic delivery capability may cause problems with correct operation.
-  The ambient temperature should be within the range of 5°C to 35°C during use. Temperatures which are lower or higher than this may cause problems with correct operation.
-  The relative humidity should be within the range of 45% to 85% during use, and no dew formation should occur in any devices. Excessively dry or humid environments and dew formation may cause problems with correct operation.
-  In the event of an electrical storm, turn off the power and disconnect the power cord from the wall outlet. Lightning may cause problems with correct operation.

#### Installation



-  Machine installation should only be carried out by a qualified technician.
-  Contact your Brother dealer or a qualified electrician for any electrical work that may need to be done.
-  The sewing machine weighs approximately 160 kg. Use equipment such as a crane or hoist when installing the machine head and adjusting the height of the table. If you try to lift the machine head yourself, it may cause injuries such as back injury.
-  Do not connect the power cord until installation is complete. If the foot switch is depressed by mistake, the sewing machine might start operating and injury could result.
-  Hold the machine head with both hands when tilting it back or returning it to its original position. In addition, do not subject the machine head to extra force while it is tilted back. If this is not observed, the machine head may become unbalanced and fall down, and serious injury or damage to the sewing machine may result.
-  Be sure to connect the ground. If the ground connection is not secure, you run a high risk of receiving a serious electric shock, and problems with correct operation may also occur.
-  All cords should be secured at least 25 mm away from any moving parts. Furthermore, do not excessively bend the cords or secure them too firmly with staples, otherwise there is the danger that fire or electric shocks could occur.
-  Install the safety covers to the machine head and motor.
-  If using a work table which has casters, the casters should be secured in such a way so that they cannot move.
-  Use a table with a height of 84 cm or less. If the table is too high, the machine head may become unbalanced and fall down, and serious injury or damage to the sewing machine may result.
-  Be sure to wear protective goggles and gloves when handling the lubricating oil and grease, so that they do not get into your eyes or onto your skin. If the oil and grease get into your eyes or onto your skin, inflammation can result. Furthermore, do not drink or eat the lubricating oil or grease. They may cause diarrhea or vomiting. Keep the oil out of the reach of children.

## CAUTION









### Sewing

-  This sewing machine should only be used by operators who have received the necessary training in safe use beforehand.
-  The sewing machine should not be used for any applications other than sewing.
-  Be sure to wear protective goggles when using the machine.  
If goggles are not worn, there is the danger that if a needle breaks, parts of the broken needle may enter your eyes and injury may result.
-  Turn off the power switch at the following times. If the foot switch is depressed by mistake, the sewing machine might start operating and injury could result.
  - When threading the needle
  - When replacing the bobbin and needle
  - When not using the machine and when leaving the machine unattended
-  If using a work table which has casters, the casters should be secured in such a way so that they cannot move.
-  Attach all safety devices before using the sewing machine. If the machine is used without these devices attached, injury may result.
-  Do not touch any of the moving parts or press any objects against the machine while sewing, as this may result in personal injury or damage to the machine.
-  If an error occurs in machine operation, or if abnormal noises or smells are noticed, immediately turn off the power switch. Then contact your nearest Brother dealer or a qualified technician.
-  If the machine develops a problem, contact your nearest Brother dealer or a qualified technician.

### Cleaning

-  Turn off the power switch before carrying out cleaning. If the foot switch is depressed by mistake, the sewing machine might start operating and injury could result.
-  Be sure to wear protective goggles and gloves when handling the lubricating oil and grease, so that they do not get into your eyes or onto your skin. If the oil and grease get into your eyes or onto your skin, inflammation can result.  
Furthermore, do not drink or eat the lubricating oil or grease. They may cause diarrhea or vomiting.  
Keep the oil out of the reach of children.

### Maintenance and inspection

-  Maintenance and inspection of the sewing machine should only be carried out by a qualified technician.
-  Ask your Brother dealer or a qualified electrician to carry out any maintenance and inspection of the electrical system.
-  Turn off the power switch and disconnect the power cord before carrying out the following operations. If the foot switch is depressed by mistake, the sewing machine might start operating and injury could result.
  - Inspection, adjustment and maintenance
  - Replacing consumable parts such as the rotary hook
-  Disconnect the air hoses from the air supply and wait for the needle on the pressure gauge to drop to "0" before carrying out inspection, adjustment and repair of any parts which use the pneumatic equipment.
-  Hold the machine head with both hands when tilting it back or returning it to its original position.  
In addition, do not subject the machine head to extra force while it is tilted back. If this is not observed, the machine head may become unbalanced and fall down, and serious injury or damage to the sewing machine may result.
-  If the power switch and air need to be left on when carrying out some adjustment, be extremely careful to observe all safety precautions.
-  Use only the proper replacement parts as specified by Brother.
-  If any safety devices have been removed, be absolutely sure to re-install them to their original positions and check that they operate correctly before using the machine.
-  Any problems in machine operation which result from unauthorized modifications to the machine will not be covered by the warranty.

### [3] Warning labels

The following warning labels appear on the sewing machine. Please follow the instructions on the labels at all times when using the machine. If the labels have been removed or are difficult to read, please contact your nearest Brother dealer.

**1**

|  |  |   |
|--|--|---|
|  | <b>⚠ 危険 ⚠ 危険</b>   |   |
|  | 高電圧部分にふれて、大けがをすることがある。電源を切り、5分たってからカバーをはずすこと。  | 触摸高压电部分, 会导致受伤。在切断电源5分钟后, 再开启盖罩。  |
| <b>⚠ DANGER</b>  | <b>⚠ GEFAHR</b>  | <b>⚠ DANGER</b>   |
| Hazardous voltage will cause injury. Turn off main switch and wait 5minutes before opening this cover. | Hochspannung verletzungsgefahr! Bitte schalten sie den hauptschalter aus und warten sie 5 minuten, bevor sie diese abdeckung öffnen. | Un voltage non adapte provoque des blessures. Eteindre l'interrupteur et attendre 5 minutes avant d'ouvrir le capot.                |
|  |  | Un voltaje inadecuado puede provocar las heridas. Apagar el interruptor principal y esperar 5 minutos antes de abrir esta cubierta. |

**2**

|  |   |
|--|---|
|  | <b>⚠ 注意</b>   |
|  | 触摸运动部分, 易造成受伤。所以在装上安全保护装置后, 再进行缝纫操作。在切断电源后, 进行穿线, 更换梭芯, 机针和做清扫, 调整工作。 |
| <b>⚠ CAUTION</b>   |   |
| Moving parts may cause injury. Operate with safety devices. Turn off main switch before threading, changing bobbin and needle, cleaning etc. |   |

**3** Be careful to avoid getting hands caught in sliding parts.

Safety devices:

Devices such as eye guard, finger guard, thread take-up cover, motor cover, X motor cover, tension release solenoid cover, inside cover, outside cover, middle cover, fixed cover and rear cover

**4** **PE** Be sure to connect the ground. If the ground connection is not secure, you run a high risk of receiving a serious electric shock, and problems with correct operation may also occur.

**5** Direction of operation

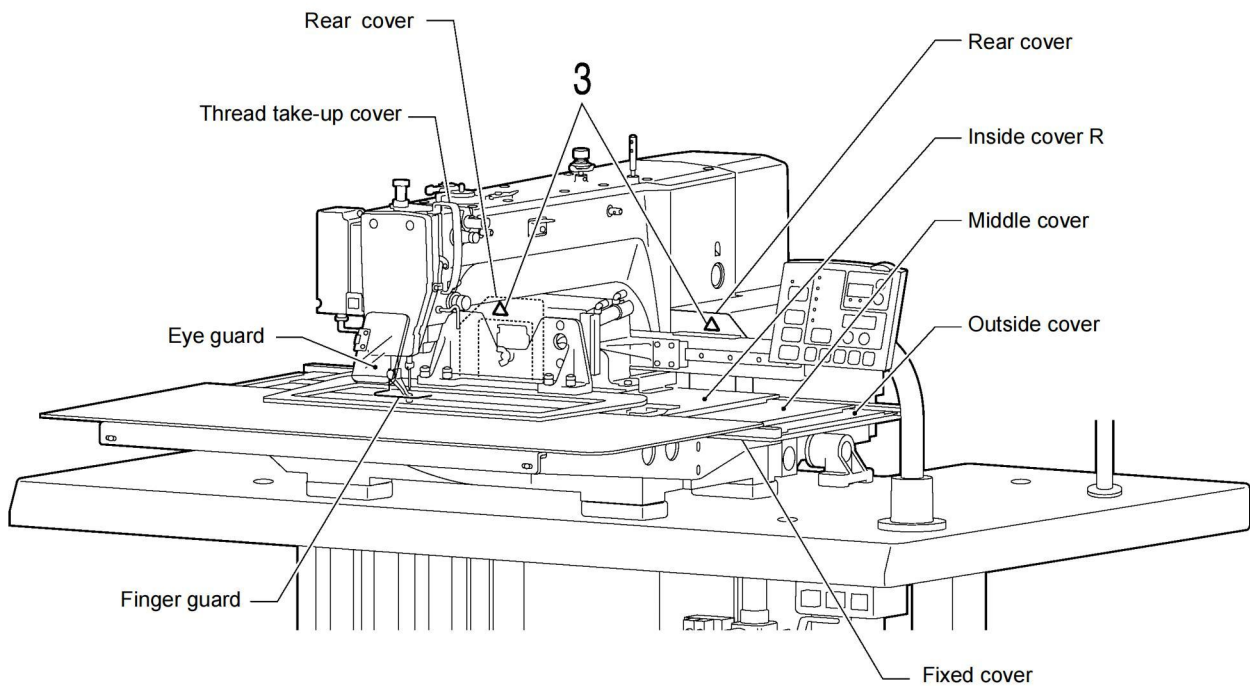

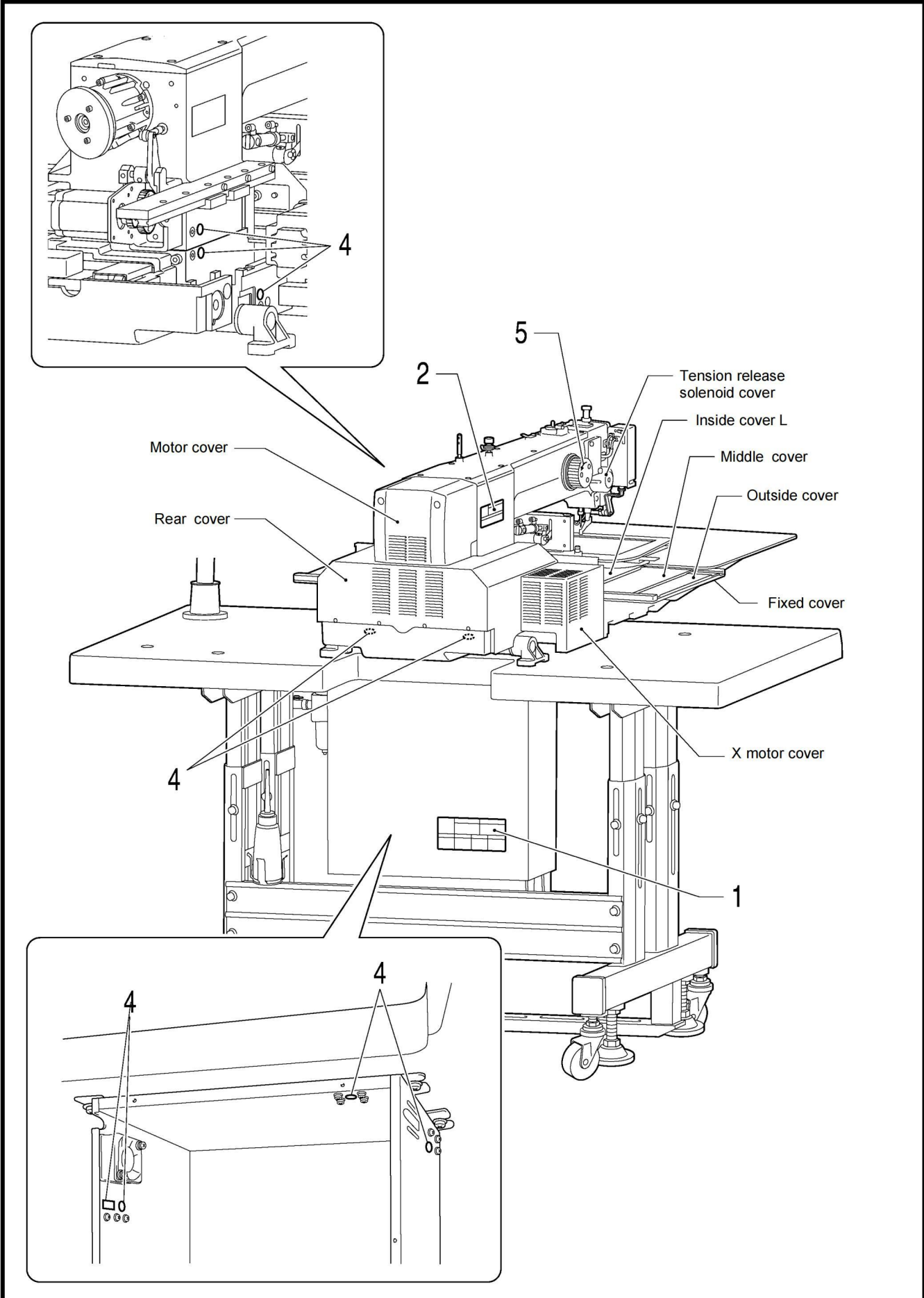



# CONTENTS

|  |           |   |           |
|--|-----------|---|-----------|
| <b>1. NAMES OF MAJOR PARTS .....</b>                   | <b>1</b>  | <b>7. CLEANING .....</b>  | <b>21</b> |
| <b>2. SPECIFICATIONS .....</b>                         | <b>2</b>  | 7-1. Cleaning the rotary hook .....                               | 21        |
| <b>3. TABLE PROCESSING DIAGRAM .....</b>               | <b>3</b>  | 7-2. Draining the oil.....  | 21        |
| <b>4. INSTALLATION.....</b>                            | <b>4</b>  | 7-3. Checking the regulator .....                                 | 22        |
| 4-1. Removing the machine head fixing bolts .....      | 4         | 7-4. Cleaning the control box air inlet ports.....                | 22        |
| 4-2. Installing the control box .....                  | 5         | 7-5. Cleaning the eye guard .....                                 | 22        |
| 4-3. Installing the oil pan and support lever base.... | 6         | 7-6. Checking the needle.....                                     | 22        |
| 4-4. Installing the machine head.....                  | 6         | 7-7. Lubrication .....  | 22        |
| 4-5. Tilting back and returning the machine head ...   | 7         | <b>8. STANDARD ADJUSTMENTS .....</b>                              | <b>23</b> |
| 4-6. Installing the gas spring.....                    | 8         | 8-1. Adjusting the thread take-up spring.....                     | 23        |
| 4-7. Securing the cords and air tubes .....            | 9         | 8-2. Adjusting arm thread guide R.....                            | 24        |
| 4-8. Installing the eye guard .....                    | 10        | 8-3. Adjusting the needle bar height.....                         | 24        |
| 4-9. Installing the cotton stand .....                 | 10        | 8-4. Adjusting the needle bar lift amount.....                    | 24        |
| 4-10. Lubrication .....                                | 11        | 8-5. Adjusting the driver needle guard.....                       | 25        |
| 4-11. Checking the safety switch .....                 | 12        | 8-6. Adjusting the needle clearance .....                         | 25        |
| <b>5. PREPARATION BEFORE SEWING.....</b>               | <b>13</b> | 8-7. Adjusting the shuttle race thread guide.....                 | 25        |
| 5-1. Installing the needle.....                        | 13        | 8-8. Adjusting the rotary hook lubrication amount... 26           |           |
| 5-2. Operating the 2-pedal foot switch.....            | 13        | 8-9. Adjusting the position of the movable knife.... 27           |           |
| 5-3. Threading the upper thread.....                   | 14        | 8-10. Replacing the movable and fixed knives..... 29              |           |
| 5-4. Winding the lower thread.....                     | 16        | 8-11. Adjusting the thread wiper.....                             | 31        |
| 5-5. Installing the bobbin case.....                   | 17        | 8-12. Presser foot installation position.....                     | 31        |
| 5-6. Thread tension.....                               | 18        | 8-13. Changing the intermittent stroke .....                      | 33        |
| 5-6-1. Lower thread tension.....                       | 18        | 8-14. Adjusting the work clamp lift amount.....                   | 33        |
| 5-6-2. Upper thread tension.....                       | 18        | 8-15. Adjusting the air pressure(pneumatic<br>specification)..... | 33        |
| <b>6. SEWING.....</b>                                  | <b>19</b> | <b>9. TROUBLESHOOTING.....</b>                                    | <b>34</b> |
| 6-1. Sewing.....                                       | 19        |   |           |
| 6-2. Using the STOP switch.....                        | 20        |   |           |
| 6-3. Using the thread wiper switch .....               | 20        |   |           |

# 1. NAMES OF MAJOR PARTS

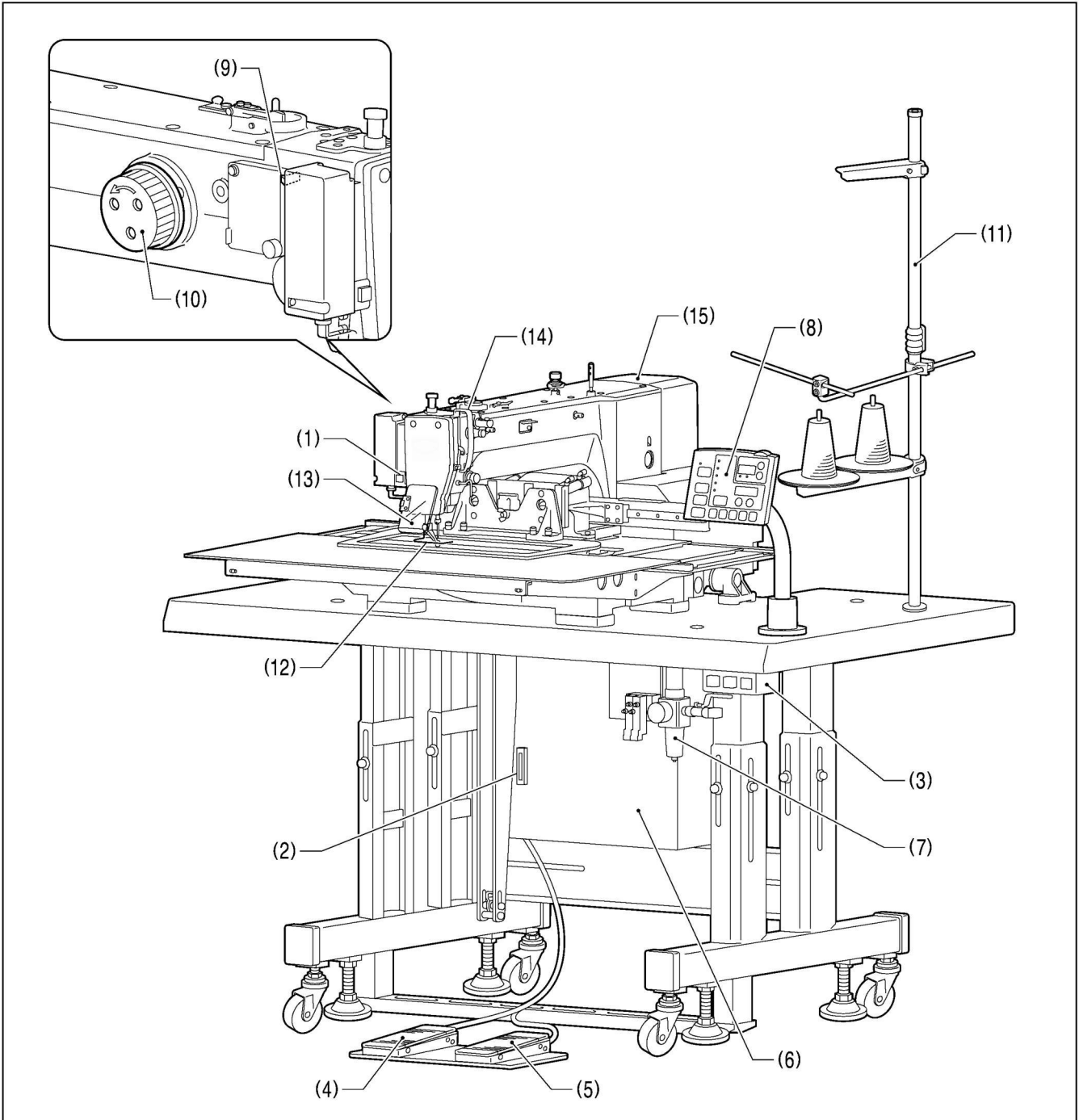

- (1) STOP switch
- (2) CF slot
- (3) Power switch
- (4) Work clamp switch
- (5) Start switch
- (6) Control box
- (7) Solenoid valve
- (8) Operation panel
- (9) Thread wiper switch
- (10) Pulley
- (11) Cotton stand

**Safety devices:**

- (12) Finger guard
- (13) Eye guard
- (14) Thread take-up cover
- (15) Motor cover

## 2. SPECIFICATIONS

|   |  |
|---|--|
| Sewing machine                              | Lock stitch, pattern tacking sewing machine (with large shuttle hook)  |
| Stitch formation                            | Single needle lock stitch  |
| Max. sewing speed                           | 2,700 rpm  |
| Sewing area (X x Y)                         | Max. 300 x 200 mm  |
| Feed mechanism                              | Intermittent feed, pulse motor drive   |
| Stitch length                               | 0.05 – 12.7 mm   |
| No. of stitches                             | 500,000-stitch internal memory (*)   |
| Maximum no. of stitches                     | 20,000 stitches (per program)  |
| No. of sewing data items that can be stored | Internal memory: 512 (*)   |
| Work clamp lift method                      | Pneumatic method   |
| Work clamp height                           | Max. 30 mm   |
| 2-step work clamp                           | Integrated-type work clamp   |
| Intermittent presser foot lift amount       | 22 mm  |
| Intermittent stroke                         | 2 – 4.5 mm, 4.5 – 10 mm or 0 (Default setting 3 mm)  |
| Rotary hook                                 | Double-capacity shuttle hook (standard shuttle hook sold separately)   |
| Wiper device                                | Standard equipment   |
| Thread trimmer                              | Standard equipment   |
| Data storage method                         | Internal memory (Flash memory), CF card (32 MB – 2 GB)<br>[Option] 3.5 floppy disk 2HD/1.44MB, 2DD                           |
| User programs                               | 999  |
| Cycle programs                              | 9  |
| Motor                                       | 750 W AC servo motor   |
| Weights                                     | Machine head approx. 160 kg, operation panel approx. 0.6 kg<br>Control box 14.2 – 16.2 kg (Differs depending on destination) |
| Power supply                                | Single-phase 220 V, Three-phase 220 V/380 V/400 V 500 VA   |
| Air pressure                                | 0.5 MPa 1.8 l/min.   |

\* The number of data items and stitches that can be stored will vary depending on the number of stitches in each program.

# 3. TABLE PROCESSING DIAGRAM

- The thickness of the table should be at least 50 mm, and it should be strong enough to bear the weight and vibration of the sewing machine.
- If using casters, use ones which can bear the total weight of sewing machine and table.
- Check that the control box is at least 10 mm away from the leg. If the control box and the leg are too close together, it may result in incorrect sewing machine operation.

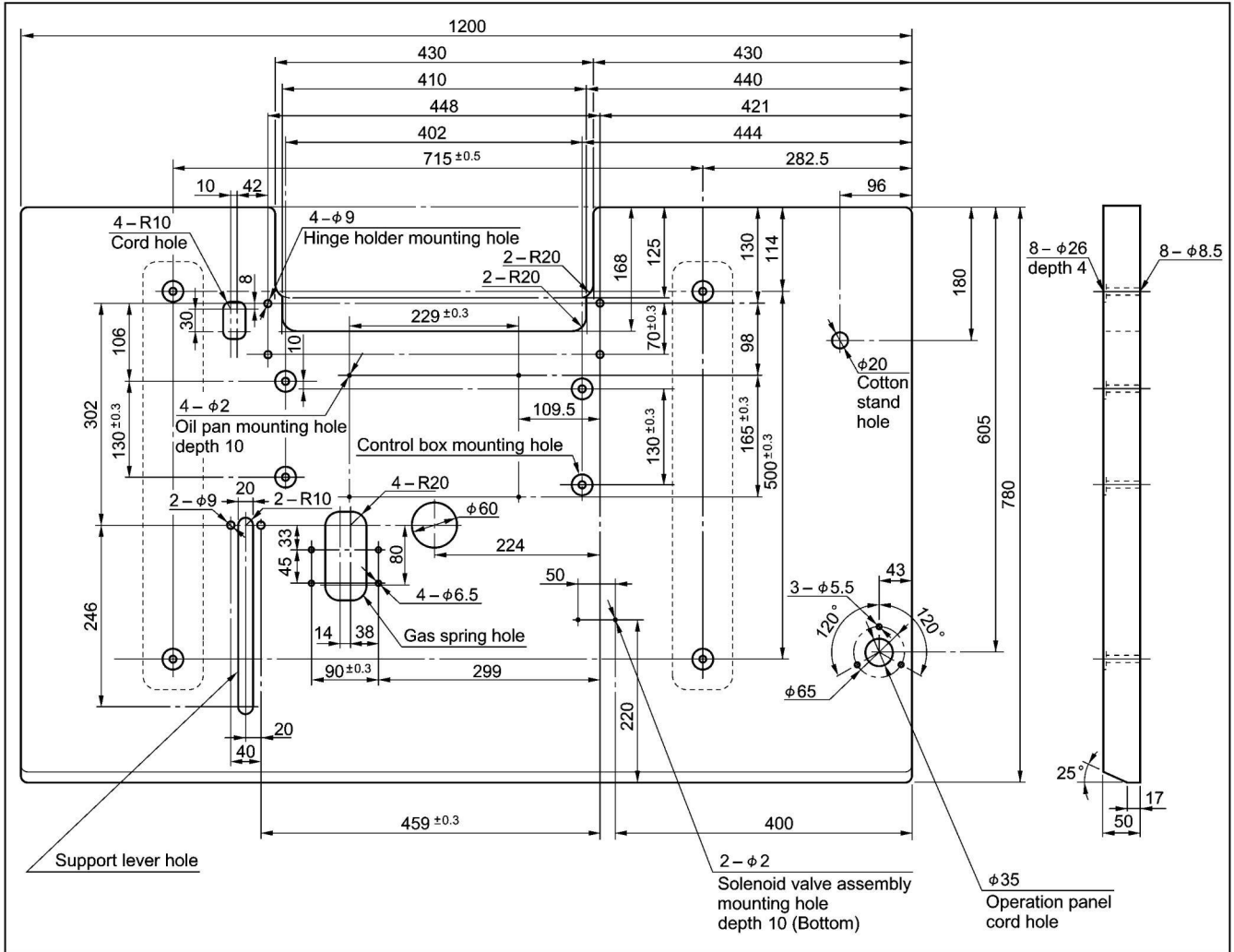

## 4. INSTALLATION

### ⚠ CAUTION

- ⊘ Machine installation should only be carried out by a qualified technician.
- ⚠ Contact your Brother dealer or a qualified electrician for any electrical work that may need to be done.
- ⚠ The sewing machine head weighs approximately 160 kg.  
Use equipment such as a crane or hoist when installing the machine head and adjusting the height of the table.  
If you try to lift the machine head yourself, it may cause injuries such as back injury.
- ⊘ Do not connect the power cord until installation is complete.  
If the foot switch is depressed by mistake, the sewing machine might start operating and injury could result.
- ⚠ If using a work table which has casters, the casters should be secured in such a way so that they cannot move.
- ⚠ Use a table with a height of 84 cm or less. If the table is too high, the machine head may become unbalanced and fall down, and serious injury or damage to the sewing machine may result.
- ⚠ Hold the machine head with both hands when tilting it back or returning it to its original position.  
In addition, do not subject the machine head to extra force while it is tilted back. If this is not observed, the machine head may become unbalanced and fall down, and serious injury or damage to the sewing machine may result.
- ⚠ All cords should be secured at least 25 mm away from any moving parts. Furthermore, do not excessively bend the cords or secure them too firmly staples, otherwise there is the danger that fire or electric shocks could occur.
- ⚠ Be sure to connect the ground. If the ground connection is not secure, you run a high risk of receiving a serious electric shock, and problems with correct operation may also occur.
- ⚠ Install the safety covers to the machine head and motor.

#### When placing the sewing machine on the table

Carry out the procedure starting from "4-2. Installing the control box" on the next page.

#### If the sewing machine was already installed to the table when it was delivered

Carry out the procedures indicated by [1] to [15] in the titles in the order of the numbers.



#### 4-1. Removing the machine head fixing bolts

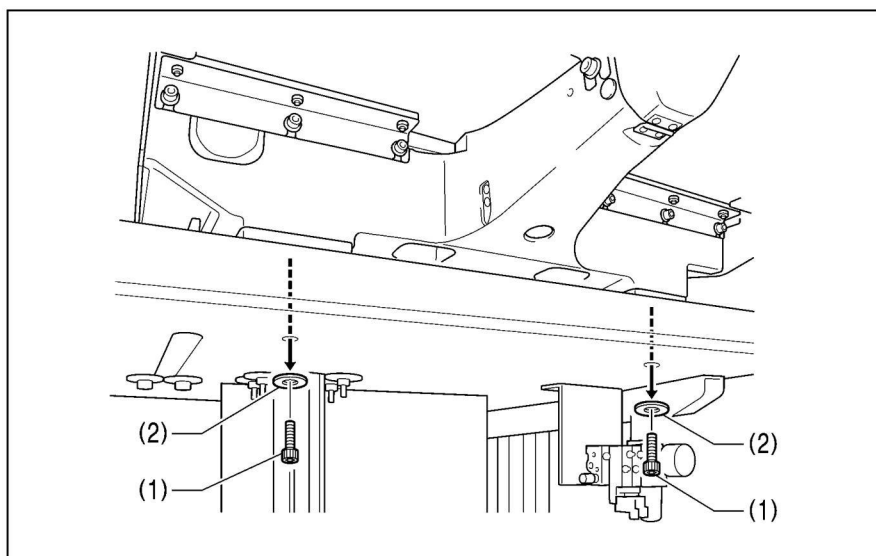

If the sewing machine was already installed to the table when it was delivered, remove the two machine head fixing bolts (1) and the two plain washers (2).

### 4-2. Installing the control box

## ! CAUTION



The control box is heavy, so installation should be carried out by two or more people. In addition, take steps to make sure that the control box does not fall down. If this is not done, injury to feet or damage to the control box may result.

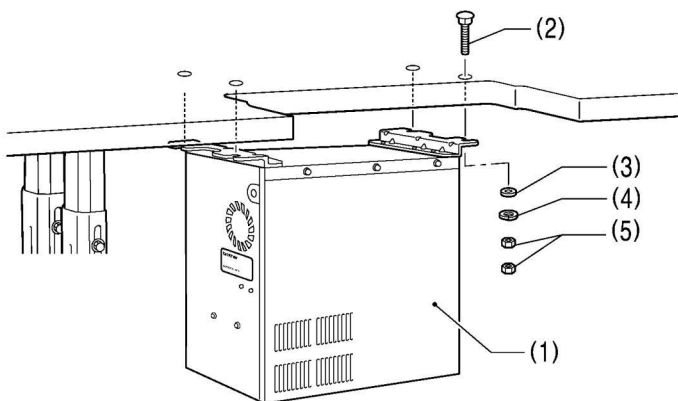

\* If the sewing machine is installed to the table, tilt back the machine head. (Refer to "4-5. Tilting back and returning the machine head".)

- (1) Control box
- (2) Bolts [4 pcs.]
- (3) Plain washers [4 pcs.]
- (4) Spring washers [4 pcs.]
- (5) Nuts [8 pcs.]

**NOTE:**  
Check that the control box (1) is at least 10 mm away from the leg. If the control box (1) and the leg are too close together, it may result in incorrect sewing machine operation.

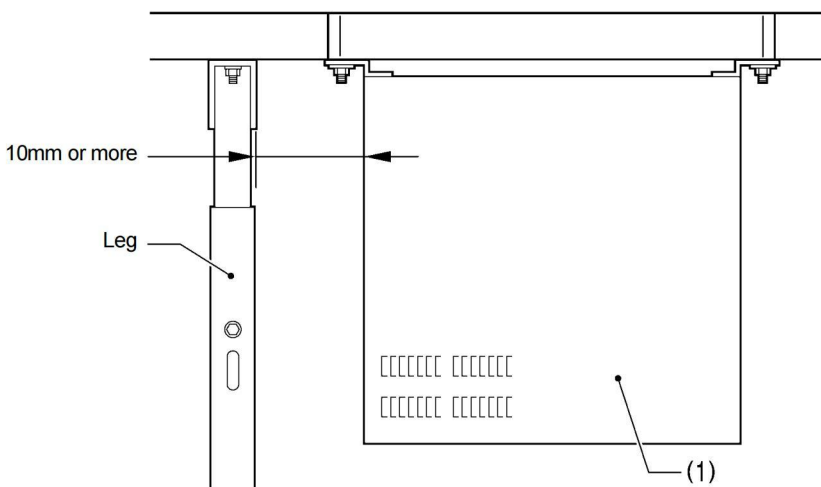

### 4-3. Installing the oil pan and support lever base

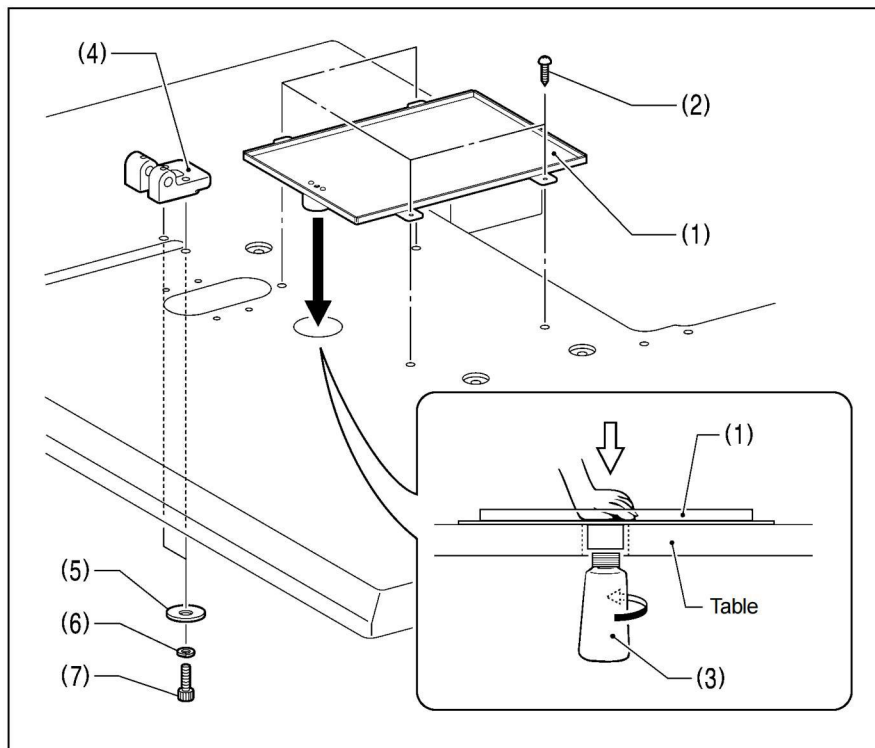

- (1) Oil pan
- (2) Wood screws [4 pcs.]
- (3) Oiler
- (4) Support lever base
- (5) Plain washers [2 pcs.]
- (6) Spring washers [2 pcs.]
- (7) Bolts [2 pcs.]

### 4-4. Installing the machine head

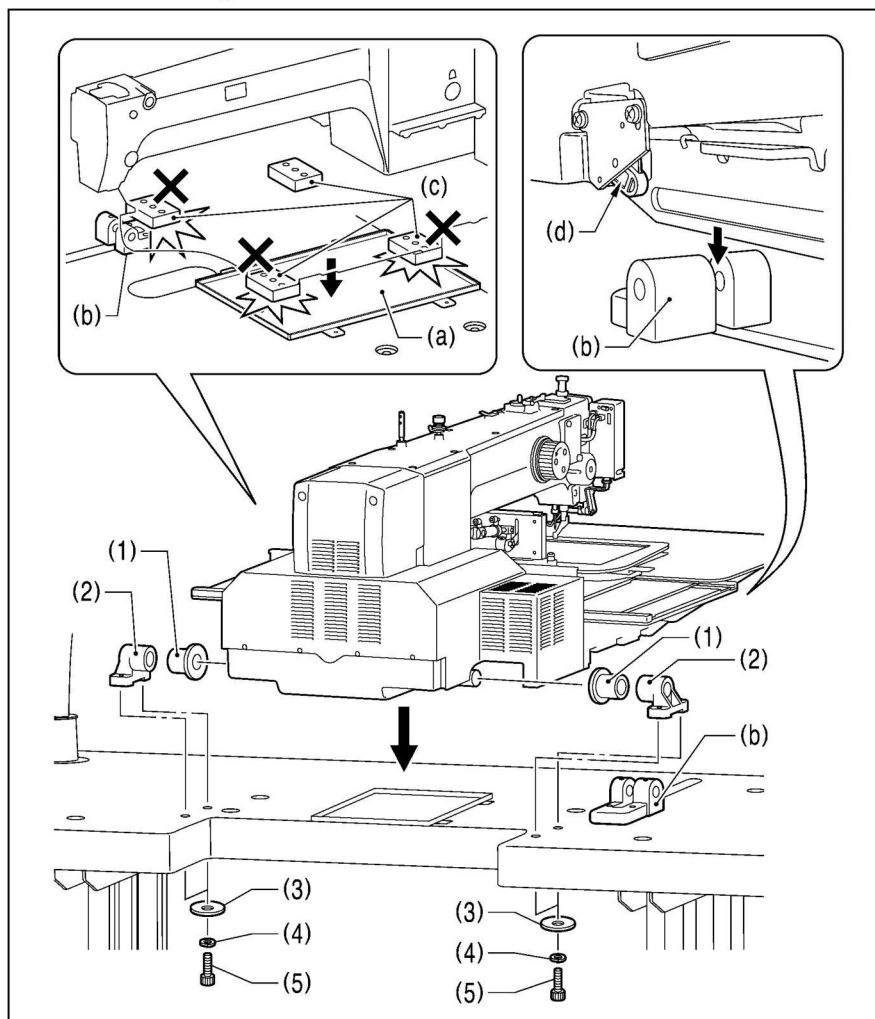

1. Place the machine head onto the table.

**NOTE:**

- Use a crane or hoist to install the sewing machine.
- Be careful of the following when lowering the machine head onto the table.
  - ! Do not let any cords get clamped between the machine head and the table.
  - ! Do not place the machine head cushion (c) on top of the oil pan (a) or the support lever base (b).
  - ! Do not let the side (d) of the safety switch lever touch the support lever base (b).

- (1) Rubber bushes (2 pcs.)
- (2) Hinge holders (2 pcs.)
- (3) Plain washers [4 pcs.]
- (4) Spring washers [4 pcs.]
- (5) Bolts [4 pcs.]

(Continued on next page)

## 4. INSTALLATION

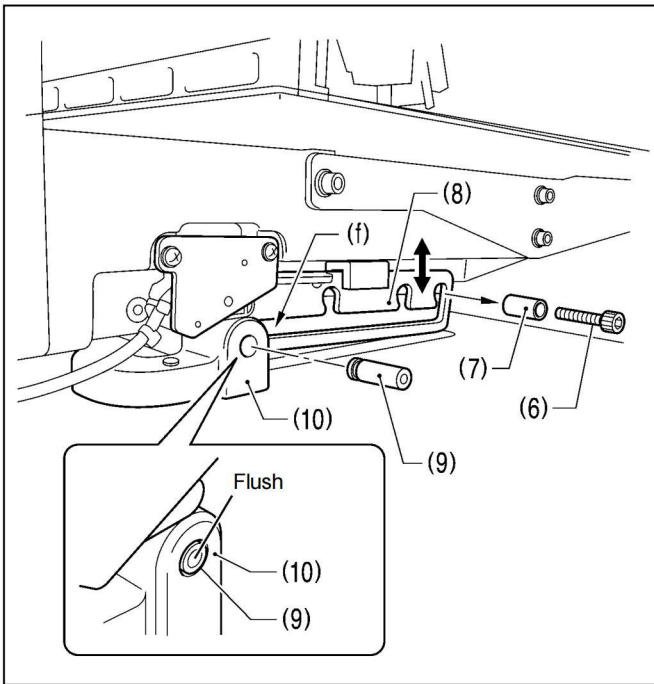

2. After placing the machine head onto the table, remove the bolt (6) and the spacer (7).

\* The bolt (6) and the spacer (7) are necessary for securing the support lever (8) when the machine head is removed from the table, so keep them in a safe place.

3. Pass the support lever shaft (9) through the hole in the support lever base (10) and through the groove (f) in the support lever (8), and push it in until it is flush with the surface of the support lever base (10).

\* If it is difficult to pass the support lever shaft (9) through the groove (f) in the support lever (8), move the end of the support lever (8) up and down while passing the support lever shaft (9) through.

## 4-5. Tilting back and returning the machine head

### ⚠ CAUTION



Hold the machine head with both hands when tilting it back or returning it to its original position. In addition, do not subject the machine head to extra force while it is tilted back. If this is not observed, the machine head may become unbalanced and fall down, and serious injury or damage to the sewing machine may result.



Always be sure to engage the stopper of the support lever (1) when tilting back the machine head. If the stopper is not engaged, the machine head may return to its original position and your hands may get caught and injury may result.



When disengaging the stopper, hold it by the knob (a). If you hold at the place indicated by (b), your hand will get caught between the support lever (1) and the table when the machine head is returned to its original position and injury will result.

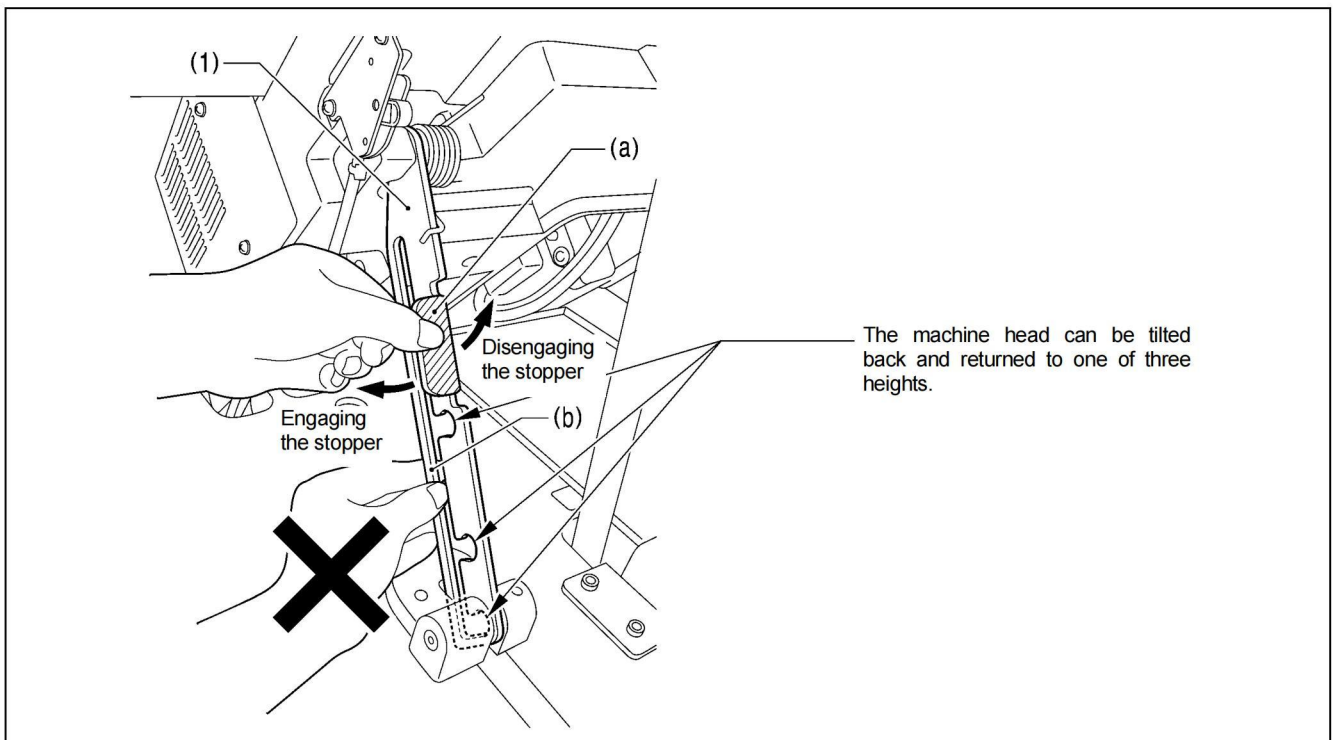

The machine head can be tilted back and returned to one of three heights.



### 4-6. Installing the gas spring

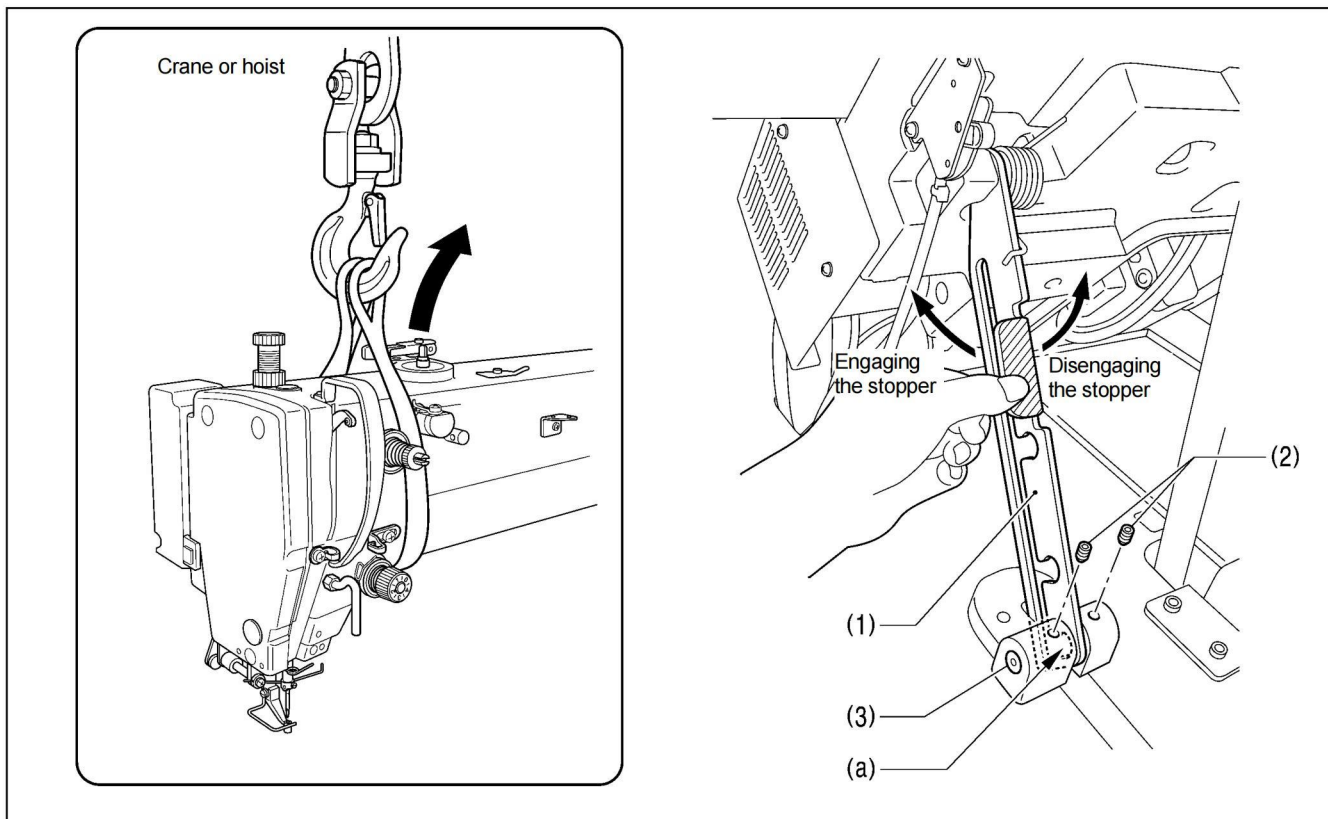

1. Tilt back the machine head, and then secure the support lever (1) at stopper position (a).  
(Refer to "4-5. Tilting back and returning the machine head".)

**NOTE:** Use equipment such as a crane or hoist to tilt back the machine head.

2. Tighten the two set screws (2) to secure the support lever shaft (3).

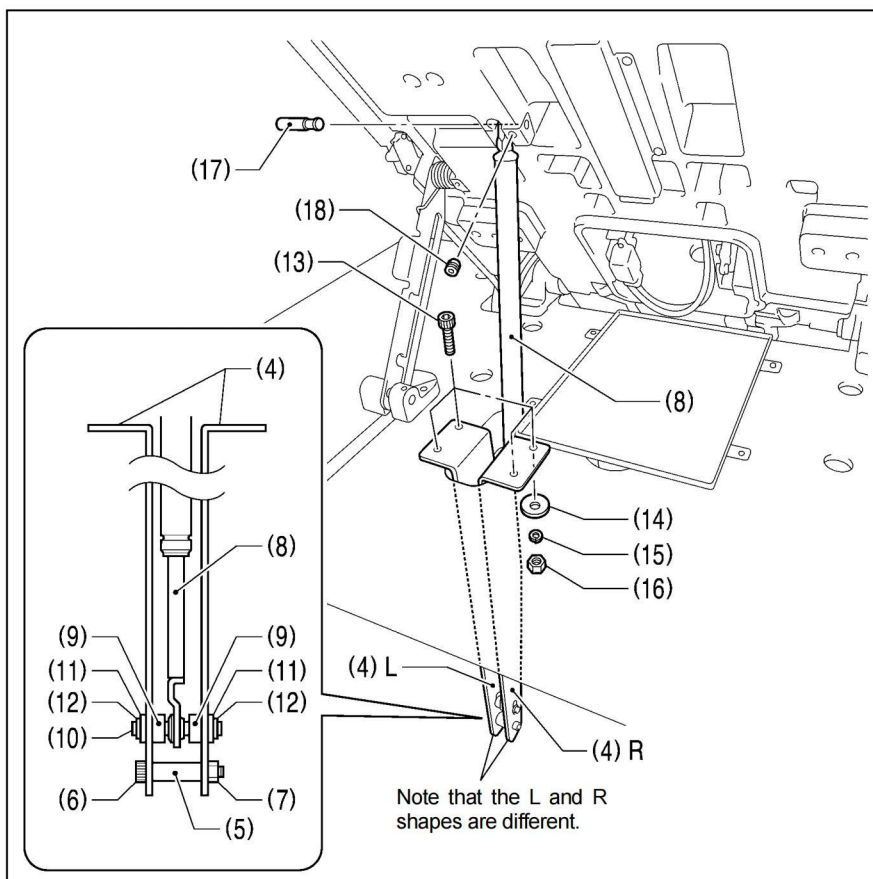

3. Install the gas spring (8).

- (4) Gas spring holders [L and R]
- (5) Spacer
- (6) Bolt
- (7) Nut
- (8) Gas spring
- (9) Shaft collars [2 pcs.]
- (10) Gas spring shaft D
- (11) Plain washers [2 pcs.]
- (12) Retaining rings E [2 pcs.]
- (13) Bolts [4 pcs.]
- (14) Plain washers [4 pcs.]
- (15) Spring washers [4 pcs.]
- (16) Nuts [4 pcs.]
- (17) Gas spring shaft U
- (18) Set screw

\* After installing the gas spring (8), gently return the machine head to its original position.  
(Refer to "4-5. Tilting back and returning the machine head".)

### 4-7. Securing the cords and air tubes

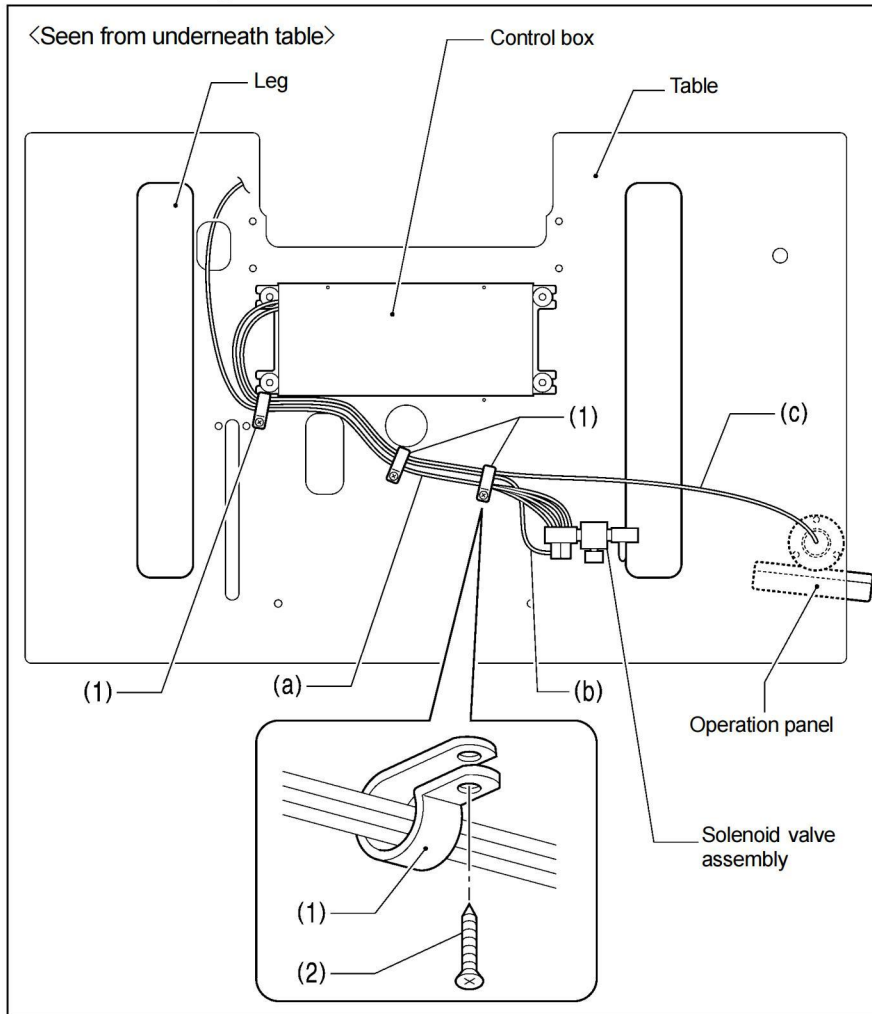

Secure the air tubes (a), the solenoid valve assembly cord (b) and the operation panel cord (c) together underneath the table with the three cord holders (1).

- (1) Cord holders [3 pcs.]
- (2) Wood screws [3 pcs.]

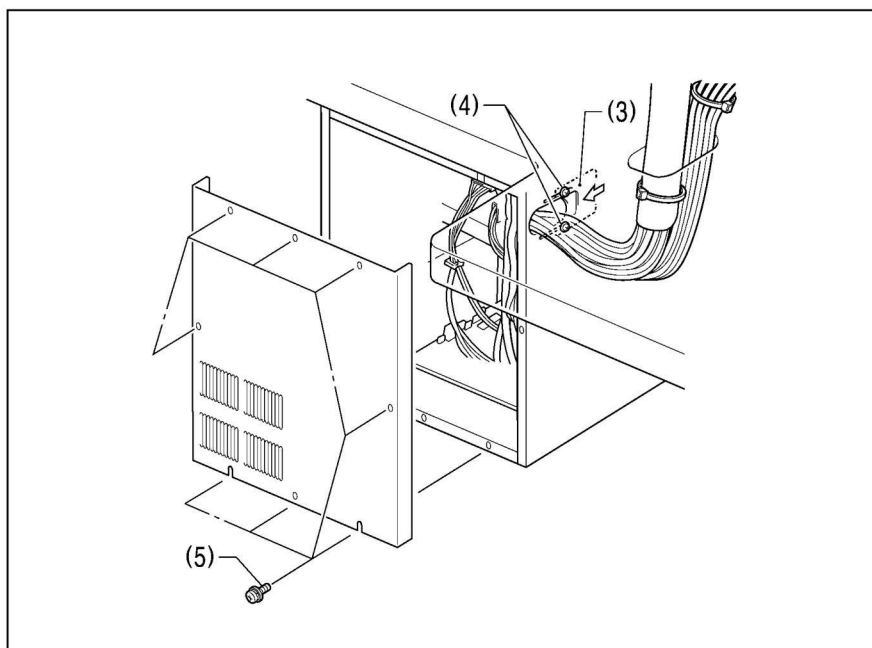

#### <Checking the cords>

1. Gently tilt back the machine head. (Refer to "4-5. Tilting back and returning the machine head".)
2. Check that none of the cords are being pulled.
3. Return the machine head to its original position.
4. Close the cord presser plate (3) in the direction of the arrow, and secure it by tightening the two screws (4).

**NOTE:**

Tighten the cord presser plate (3) securely so that no foreign objects or small animals can get inside the control box.

5. Secure the cover of the control box by tightening the eight screws (5). Check that the cords are not clamped by the cover at this time.

## 4-8. Installing the eye guard

### CAUTION



Attach all safety devices before using the sewing machine.  
If the machine is used without these devices attached, injury may result.

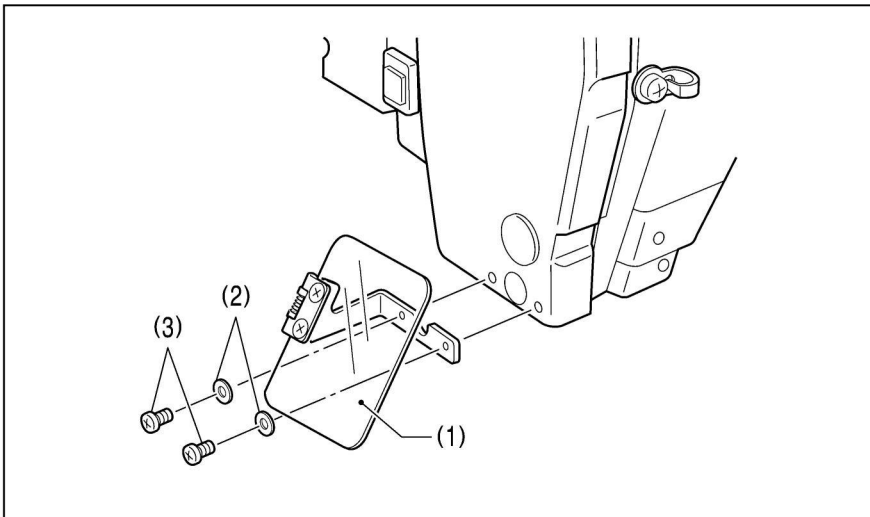

- (1) Eye guard assembly
- (2) Plain washers [2 pcs.]
- (3) Screws [2 pcs.]

## 4-9. Installing the cotton stand

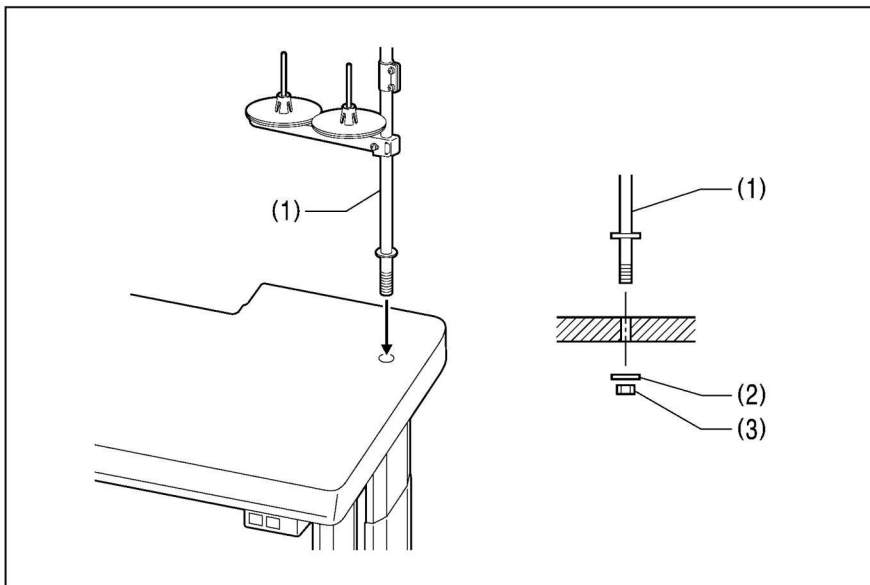

- (1) Cotton stand

### NOTE:

Fit the washer (2), and then securely tighten the nut (3) so that the cotton stand does not move.

## 4-10. Lubrication

### CAUTION



Do not connect the power cord until lubrication is complete.

If the foot switch is depressed by mistake, the sewing machine might start operating and injury could result.



Be sure to wear protective goggles and gloves when handling the lubricating oil and grease, so that they do not get into your eyes or onto your skin. If the oil and grease get into your eyes or onto your skin, inflammation can result.

Furthermore, do not drink or eat the lubricating oil or grease. They may cause diarrhea or vomiting.

Keep the oil out of the reach of children.

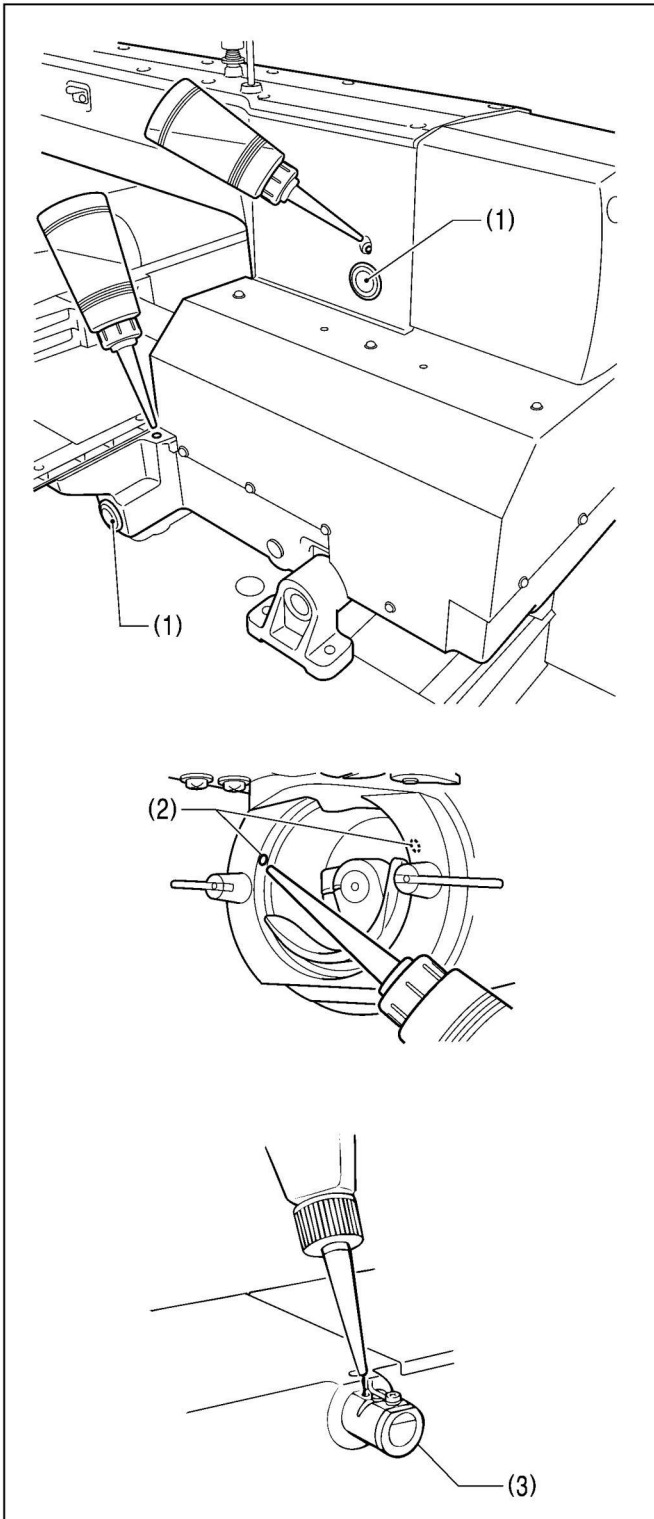

1. Fill the arm oil tank and the bed oil tank with oil.

**NOTE:**

Be sure to add more oil when the oil level drops down to about one-third full in the oil gauge window (1). If the oil drops below the one-third full level in the oil gauge window (1), there is the danger that the sewing machine may seize during operation.

2. Pour oil in through the two holes (2) of the shuttle race base assembly so that the felt is lightly moistened.

**NOTE:**

If there is no more oil on the felt of the shuttle race base assembly, problems with sewing may result.

3. If using the needle cooler (3), fill it with silicon oil (100 mm<sup>2</sup>/s).  
(Refer to "5-3. Threading the upper thread" for details on using the needle cooler (3).)

### 4-11. Checking the safety switch

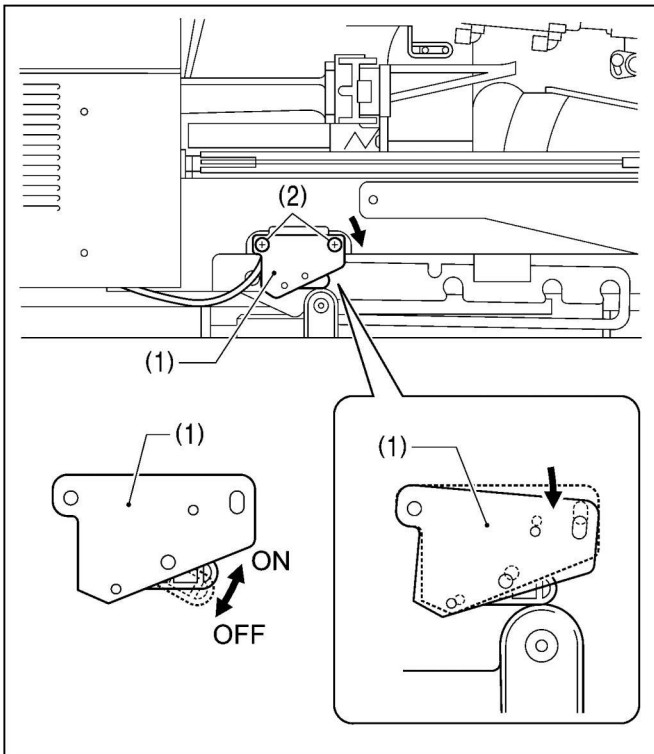

1. If the machine head is tilted back, gently return it to its original position. (Refer to "4-5. Tilting back and returning the machine head".)
2. Turn on the power switch.
3. Check that no error numbers are displayed on the operation panel.

If the safety switch (1) is not turned on, error [E050], [E051] or [E055] will occur.

Check the installation position of the safety switch (1).

1. Turn off the power switch.
2. Loosen the two screws (2).
3. Push down the right side of the safety switch (1) as far as possible so that the safety switch (1) turns on, and then tighten the two screws (2).
4. Turn on the power and check that no error numbers are displayed.

## 5. PREPARATION BEFORE SEWING

### 5-1. Installing the needle

#### ⚠ CAUTION



Turn off the power switch before installing the needle.

If the foot switch is depressed by mistake, the sewing machine might start operating and injury could result.

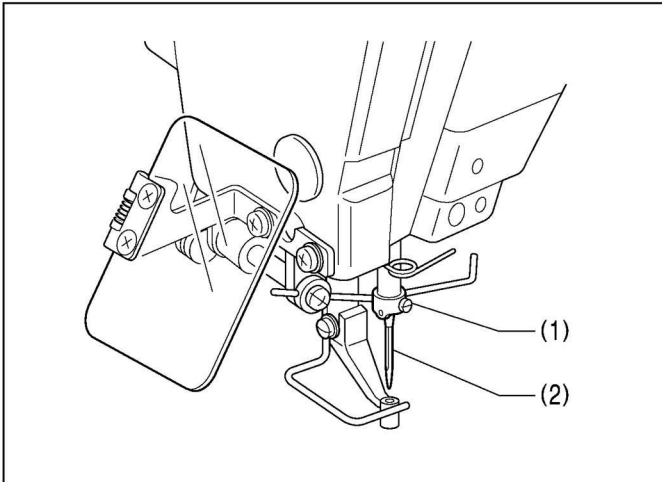

1. Loosen the set screw (1).
2. Insert the needle (2) in a straight line as far as it will go, making sure that the long groove on the needle is at the front, and then securely tighten the set screw (1).

### 5-2. Operating the 2-pedal foot switch

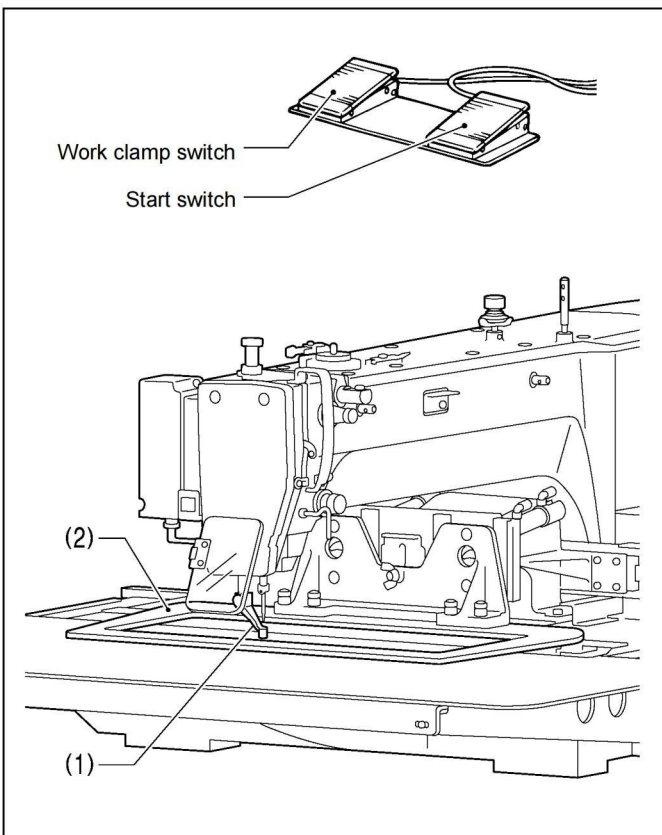

When the work clamp switch (left side) is depressed, the intermittent presser foot (1) and the work clamp (2) are lowered, and when the start switch (right side) is then depressed, the sewing machine starts operating.

\* The work clamp (2) lowering method can be changed using memory switch No. 002. (Refer to "7-3. List of memory switch settings.")

### 5-3. Threading the upper thread

Thread the upper thread correctly as shown in the illustration below.

\* When using threading mode for threading, the tension discs (1) will open so that the thread can be threaded more easily. (Refer to following page.)

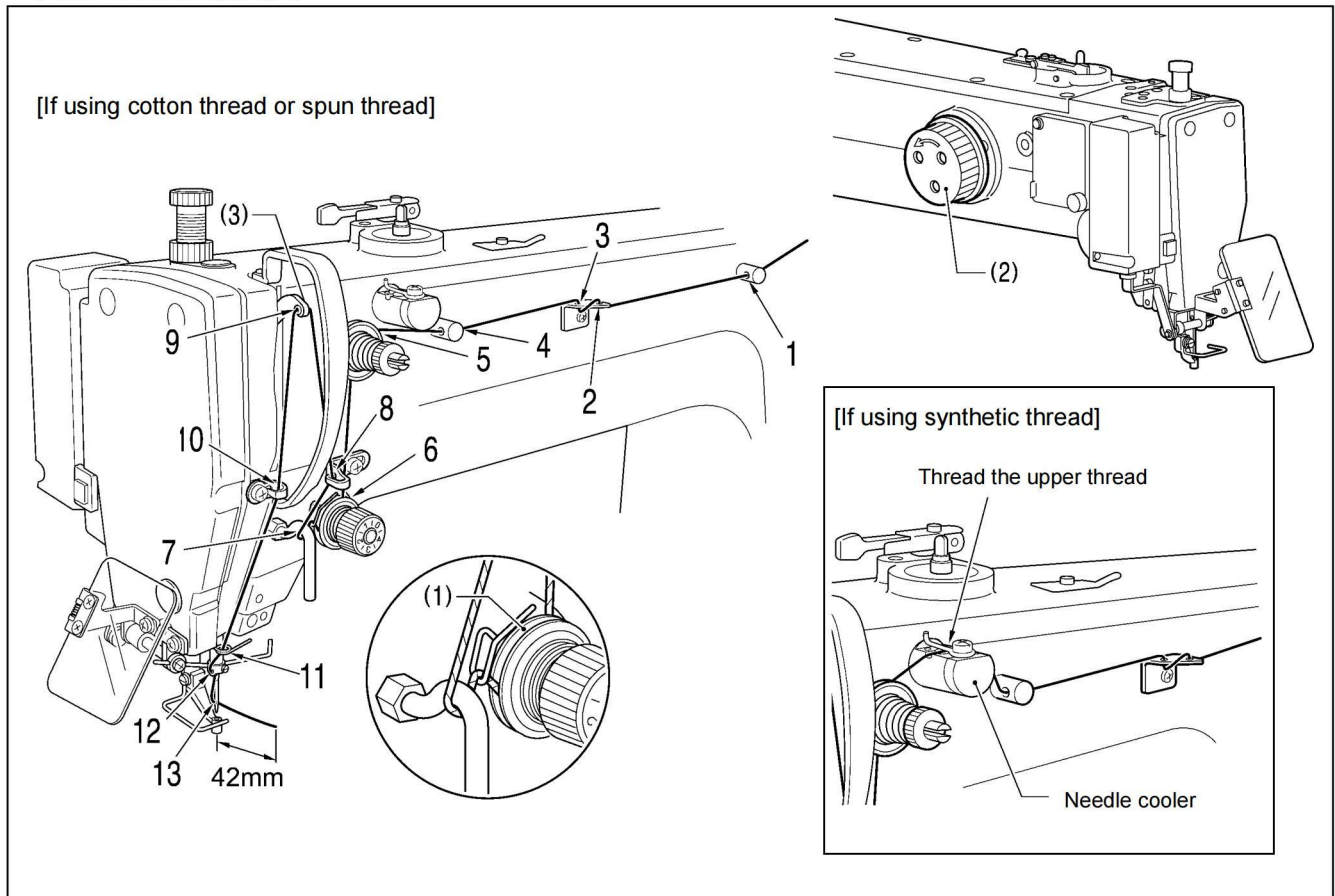





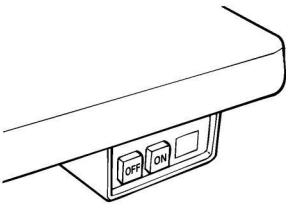

- Turn the machine pulley (2) and raise the thread take-up (3) to its highest position before threading the upper thread. (This will make threading easier and it will prevent the thread from coming out at the sewing start.)
- When threading the thread through the needle, allow a distance of approximately 42 mm between the needle hole and the end of the thread.  
If the trailing length of the thread is too long, it may cause the thread to become tangled.

## 5. PREPARATION BEFORE SEWING

### <Threading mode>

Threading mode is safe because the sewing machine will not start even when the foot switch is depressed.

|   |  |
|---|--|
| 1 |  <p>Turn on the power switch.</p>   |
| 2 | <p>Press the home position key</p>  <p>Press the threading key, and key.</p>   <ul style="list-style-type: none"><li>• The work clamp will drop.</li></ul> |
| 3 | <p>Threading the thread.</p>   |
| 4 | <p>Ending threading mode</p> <p>Press the threading key, and the key change</p>   <ul style="list-style-type: none"><li>• The work clamp will return to where it was before threading mode was started.</li></ul>                       |



### 5-4. Winding the lower thread

## ! CAUTION



Do not touch any of the moving parts or press any objects against the machine while winding the lower thread. Injury or damage to the sewing machine may result.

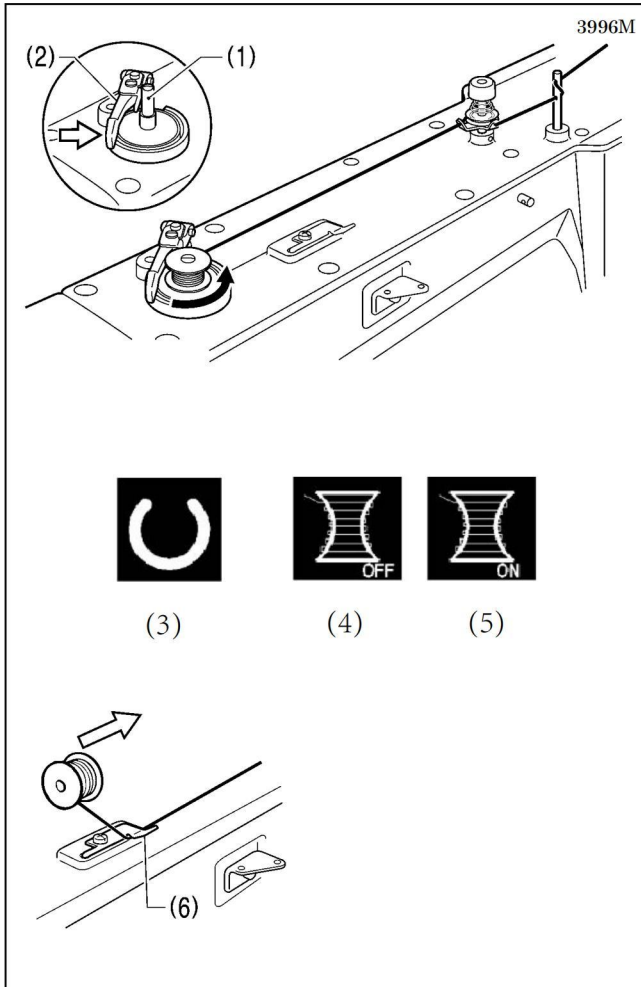

1. Place the bobbin onto the bobbin winder shaft (1).
2. Thread the thread as shown in the illustration, wind the thread around the bobbin several times, and then press the bobbin presser arm (2).
3. Turn on the power switch.
4. Depress the work clamp switch (3) to lower the work clamp, and then depress the start switch (4). (Home position detection will be carried out.)
5. Check that the needle is not touch the clamp, and then press the bobbin winder key(4),the bobbin winder key(4) change to key(4) change to the bobbin winder key(5),and it keep in the state"on",depress the foot switch to the 2nd step,and it will start wind.  
(If using a two-pedal foot switch,depressing the start switch two-pedal foot switch.)
6. Once winding of the set amount of lower thread (80 - 90% of the bobbin capacity) is completed, the bobbin presser arm (2) will return automatically.
7. Remove the bobbin, hook the thread onto the knife (6), and then pull the bobbin in the direction of the arrow to cut the thread.

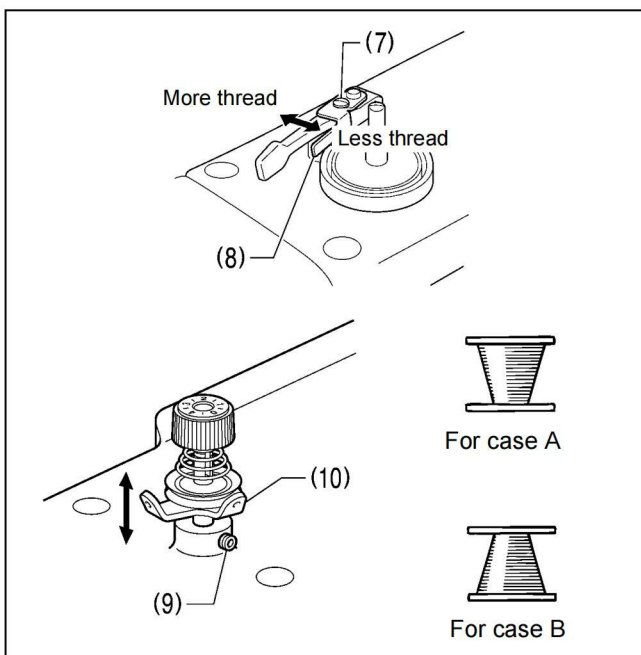

#### Adjusting the bobbin winding amount

Loosen the screw (7) and move the bobbin presser (8) to adjust.

#### If the thread winds onto the bobbin unevenly

Loosen the set screw (9) and move the bobbin winder tension assembly (10) up and down to adjust.

\* For case A, move the bobbin winder tension assembly (10) down, and for case B, move it upward.

## 5-5. Installing the bobbin case

### CAUTION



Turn off the power switch before installing the bobbin case.  
If the foot switch is depressed by mistake, the sewing machine might start operating and injury could result.

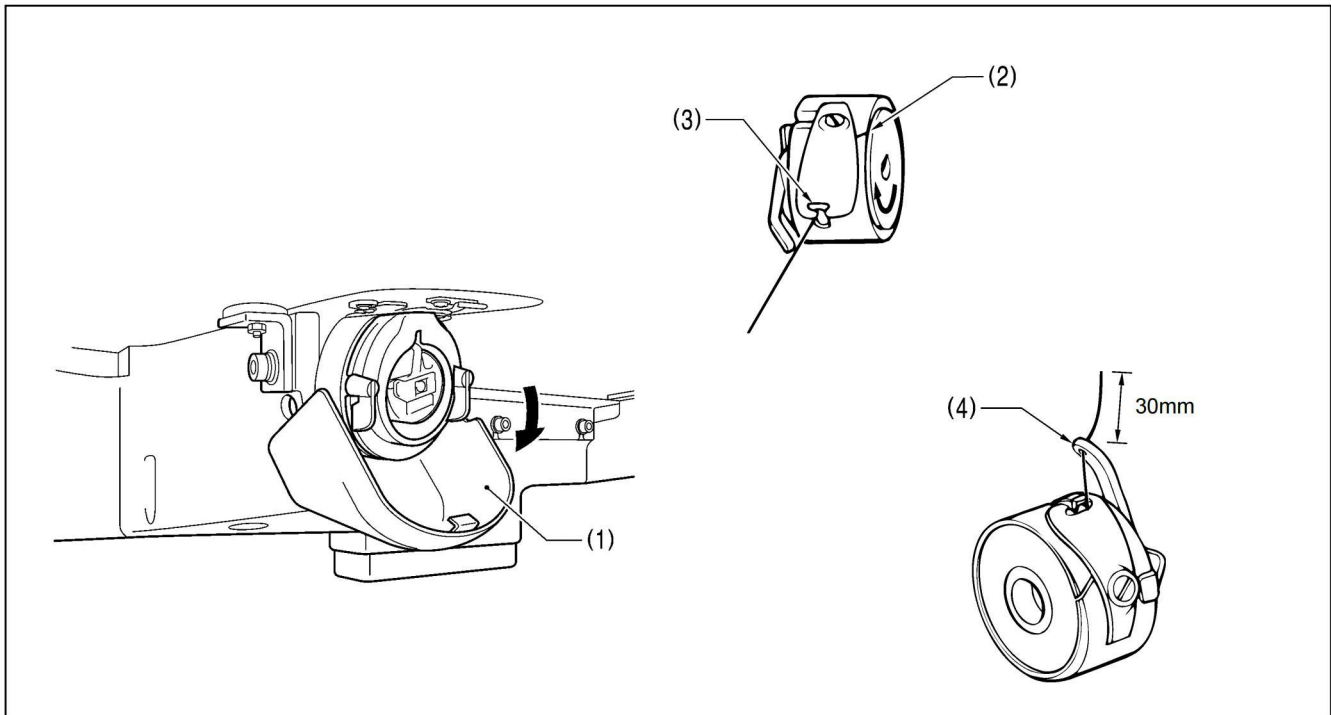

1. Pull the shuttle race cover (1) downward to open it.
2. While holding the bobbin so that the thread winds to the right, insert the bobbin into the bobbin case.
3. Pass the thread through the slot (2) and pull it out from the thread hole (3).
4. Check that the bobbin turns in the direction of the arrow when the thread is pulled.
5. Pass the thread through the lever thread hole (4), and then pull out approximately 30 mm of thread.
6. Hold the latch on the bobbin case and insert the bobbin case into the rotary hook.

## 5-6. Thread tension

### Thread tension reference

|                          |                |
|--------------------------|----------------|
| Upper thread             | #20 or similar |
| Lower thread             | #20 or similar |
| Upper thread tension (N) | 1.4 – 1.8      |
| Lower thread tension (N) | 0.3 – 0.4      |
| Pre-tension (N)          | 0.2 – 0.4      |
| Needle                   | DP × 17#19     |

### 5-6-1. Lower thread tension

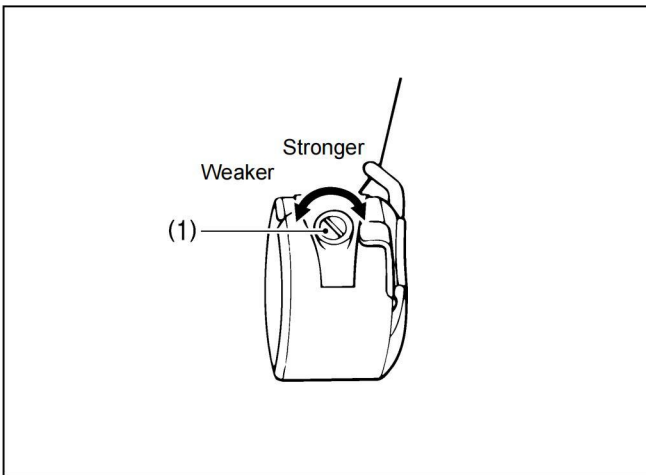

Adjust the thread tension to the weakest possible tension by turning the thread tension nut (1) until the bobbin case will not drop by its own weight while the thread end coming out of the bobbin case is held.

### 5-6-2. Upper thread tension

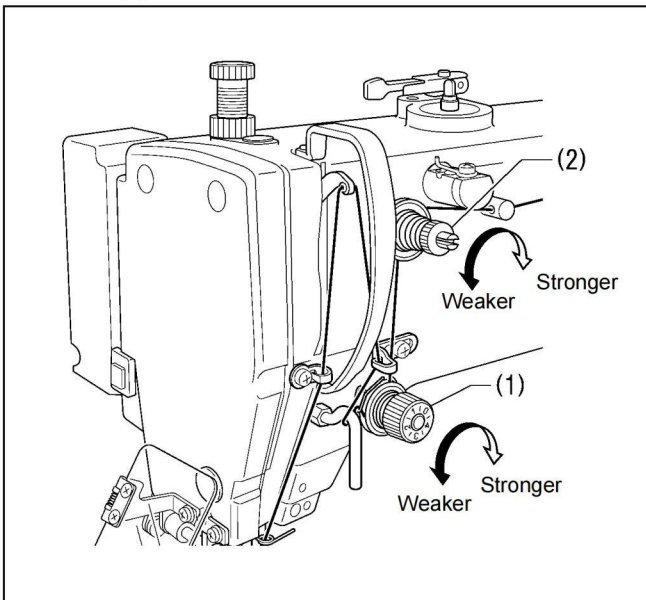

1. Turn the tension nut (1) (main tension) to adjust the tension as appropriate for the material being sewn.
2. Use the tension nut (2) (sub tension) to adjust the upper thread trailing length to about 42 mm.

## 6. SEWING

### ⚠ CAUTION



Turn off the power switch at the following times.

If the foot switch is depressed by mistake, the sewing machine might start operating and injury could result.

- When threading the needle
- When replacing the bobbin and needle
- When not using the machine and when leaving the machine unattended



Do not touch any of the moving parts or press any objects against the machine while sewing, as this may result in personal injury or damage to the machine.

### 6-1. Sewing

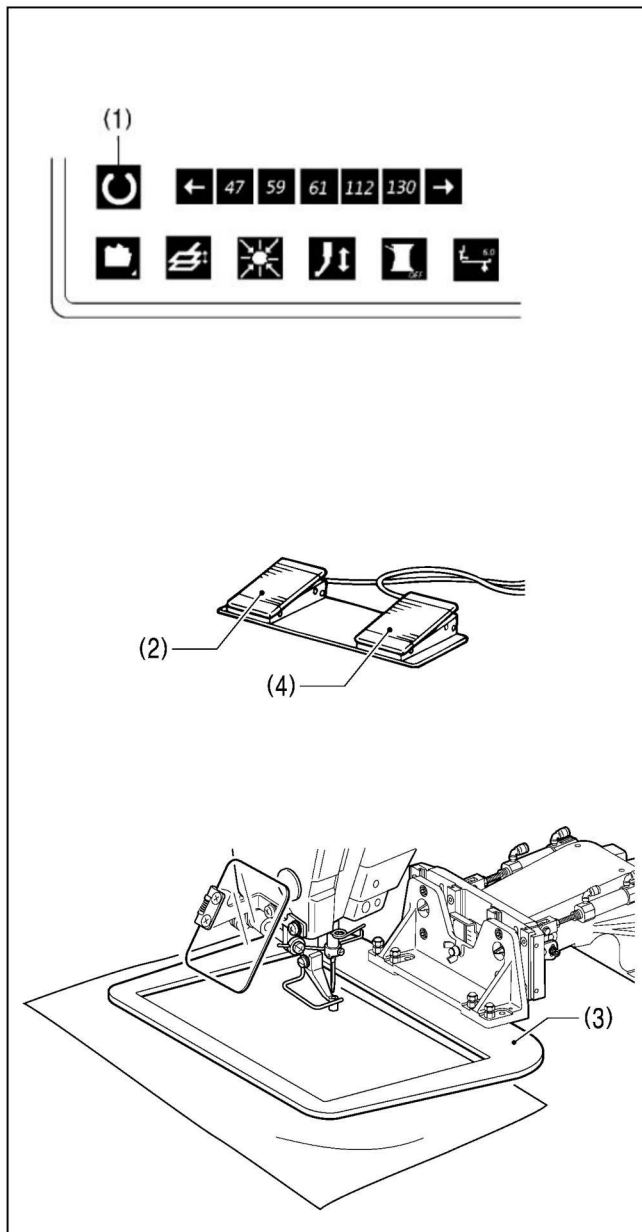

1. Turn on the power switch.
2. Press the or key to turn on the page, and press the data key to select the sewing program

3. Depress the work clamp switch (2) to lower the work clamp (3), and then depress the start switch (4).
  - The work clamp will move to the sewing start position.
  - Home position detection will be carried out immediately after the power switch is turned on.

4. Place the article to be sewn underneath the work clamp (3).
5. Depress the work clamp switch (2).
  - The work clamp (3) will drop.
6. Depress the start switch (4).
  - The sewing machine will start sewing.

7. When sewing is complete, the thread will be trimmed and the work clamp (3) will rise.

Use a work clamp and a feed plate which will hold the article securely so that it does not slip.

If using the standard work clamp and feed plate and the article being sewn is slipping, take measures to stop the work clamp and feed plate from being slippery.

## 6-2. Using the STOP switch

If you press the STOP switch (1) while sewing or test feeding is in progress, the CAUTION indicator (2) will illuminate and the sewing machine will stop immediately.

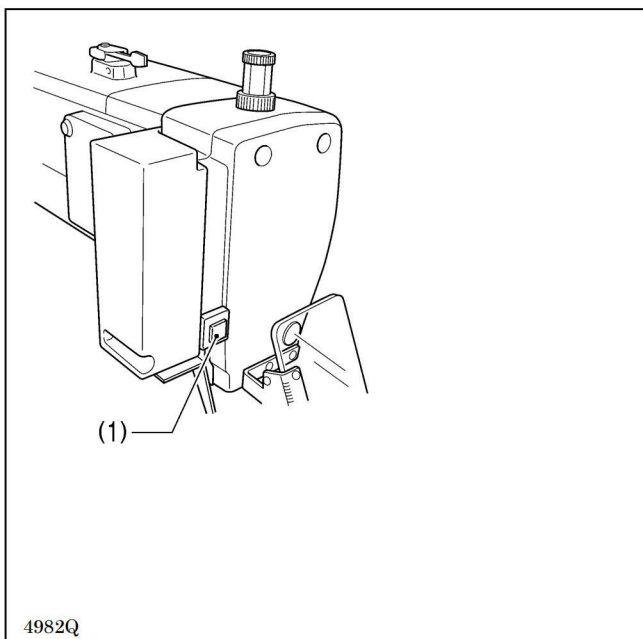

### <Continuing sewing from a stopping point>

If you have pressed the STOP switch (1) at times such as if the thread breaks while sewing or the lower thread runs out, you can resume sewing from the point where the thread ran out.

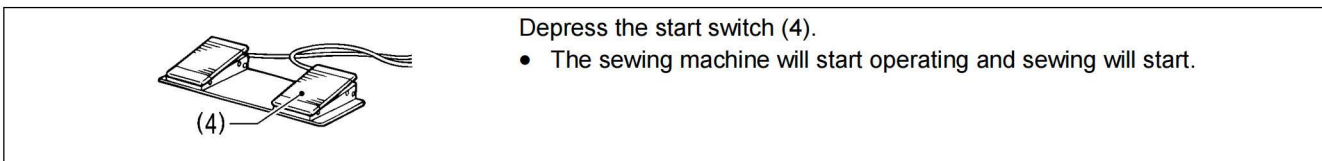

## 6-3. Using the thread wiper switch

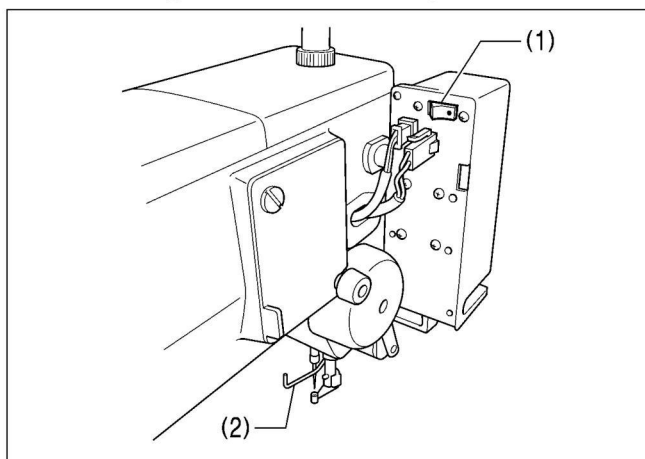

The thread wiper switch (1) can be used to turn the thread wiper (2) on and off.

## 7. CLEANING

### CAUTION



Turn off the power switch before carrying out cleaning.  
If the foot switch is depressed by mistake, the sewing machine might start operating and injury could result.



Be sure to wear protective goggles and gloves when handling the lubricating oil and grease, so that they do not get into your eyes or onto your skin. If the oil and grease get into your eyes or onto your skin, inflammation can result. Furthermore, do not drink or eat the lubricating oil or grease. They may cause diarrhea or vomiting. Keep the oil out of the reach of children.

### 7-1. Cleaning the rotary hook

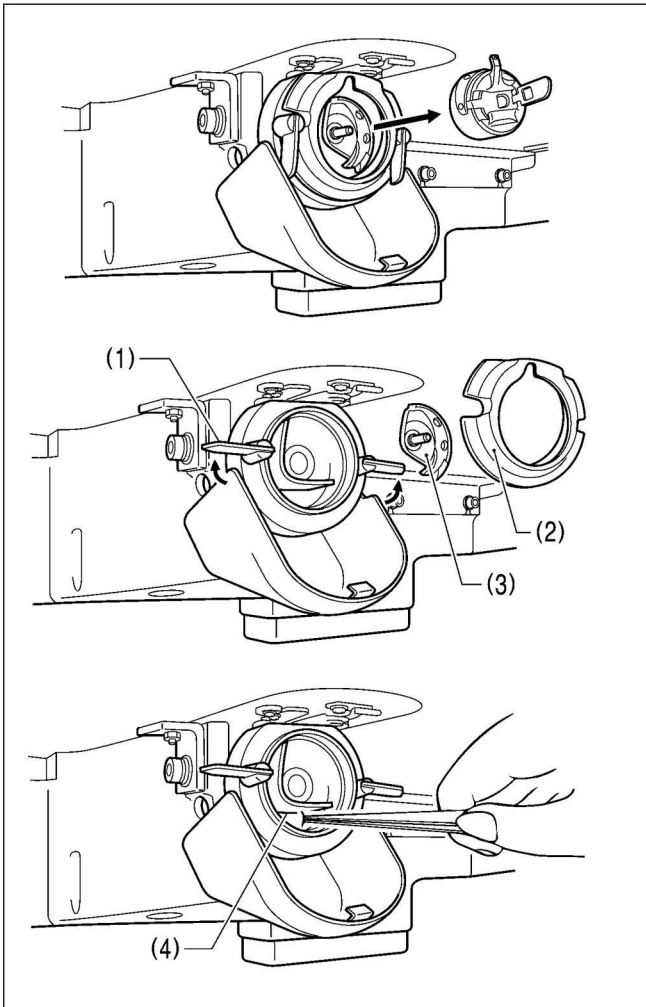

1. Pull the shuttle race cover downward to open it, and then remove the bobbin case.

2. Open the setting claw (1) in the direction indicated by the arrow, and then remove the shuttle race base (2) and the shuttle hook (3).

3. Clean all the dust and thread ends from around the driver (4), the top of the rotary hook thread guide and the shuttle race.

### 7-2. Draining the oil

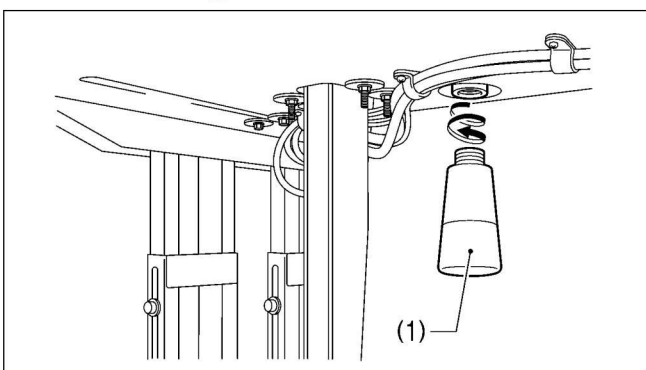

1. Remove and empty the oiler (1) whenever it is full.  
2. After emptying oiler (1), screw it back into its original position.

### 7-3. Checking the regulator

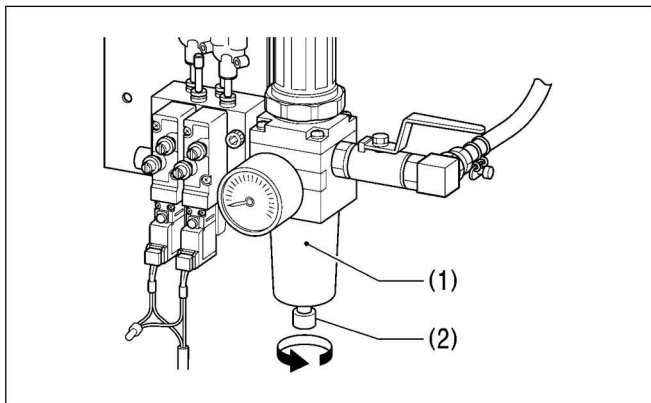

1. If water collects in the bottle of the regulator (1), turn the drain cock (2) in the direction of the arrow to drain the water.
2. After draining the water, tighten the drain cock (2).

### 7-4. Cleaning the control box air inlet ports

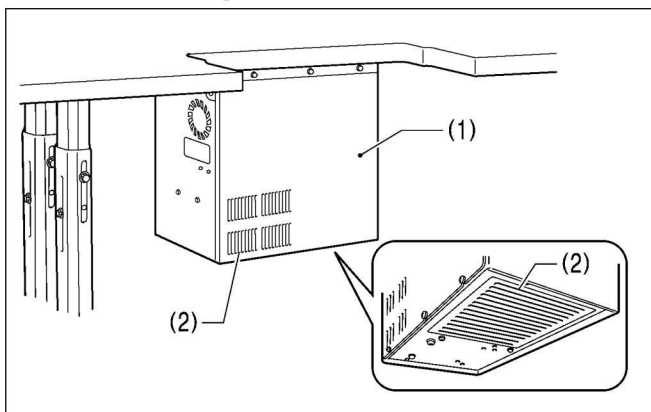

Use a vacuum cleaner to clean the filter in the air inlet ports (2) of the control box (1) at least once a month.

### 7-5. Cleaning the eye guard

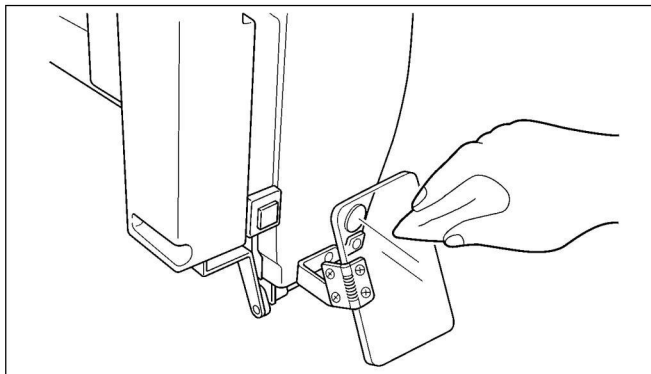

Wipe the eye guard clean with a soft cloth.

**NOTE:**

Do not use solvents such as kerosene or thinner to clean the eye guard.

### 7-6. Checking the needle

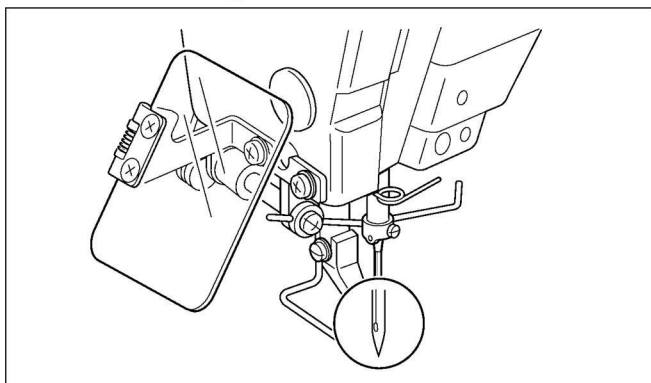









Always check that the tip of the needle is not broken and also that the needle is not bent before starting sewing.

### 7-7. Lubrication

Lubricate the sewing machine while referring to "4-18. Lubrication".

# 8. STANDARD ADJUSTMENTS

## ⚠ CAUTION

-  Maintenance and inspection of the sewing machine should only be carried out by a qualified technician.
-  Ask your Brother dealer or a qualified electrician to carry out any maintenance and inspection of the electrical system.
-  Turn off the power switch and disconnect the power cord before carrying out the following operations. If the foot switch is depressed by mistake, the sewing machine might start operating and injury could result.
  - Inspection, adjustment and maintenance
  - Replacing consumable parts such as the rotary hook
-  Disconnect the air hoses from the air supply and wait for the needle on the pressure gauge to drop to "0" before carrying out inspection, adjustment and repair of any parts which use the pneumatic equipment.
-  If the power switch and air need to be left on when carrying out some adjustment, be extremely careful to observe all safety precautions.
-  Hold the machine head with both hands when tilting it back or returning it to its original position. In addition, do not subject the machine head to extra force while it is tilted back. If this is not observed, the machine head may become unbalanced and fall down, and serious injury or damage to the sewing machine may result.
-  Be sure to wear protective goggles and gloves when handling the lubricating oil and grease, so that they do not get into your eyes or onto your skin. If the oil and grease get into your eyes or onto your skin, inflammation can result. Furthermore, do not drink or eat the lubricating oil or grease. They may cause diarrhea or vomiting. Keep the oil out of the reach of children.
-  If any safety devices have been removed, be absolutely sure to re-install them to their original positions and check that they operate correctly before using the machine.

### 8-1. Adjusting the thread take-up spring

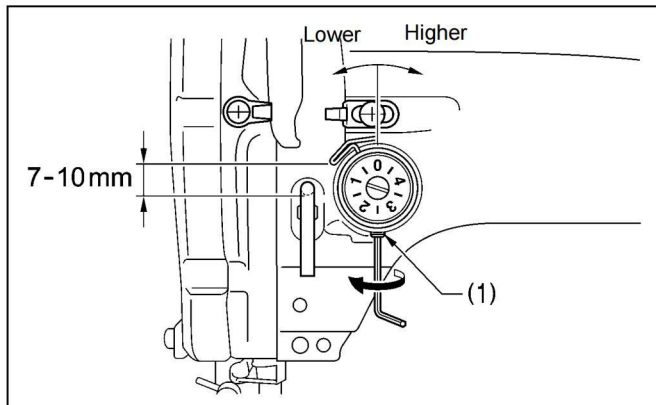

|                                   |           |
|-----------------------------------|-----------|
| Thread take-up spring height (mm) | 7 – 10    |
| Thread take-up spring tension (N) | 0.6 – 1.2 |

#### <Thread take-up spring height>

Loosen the set screw (1) and turn the adjuster to adjust.

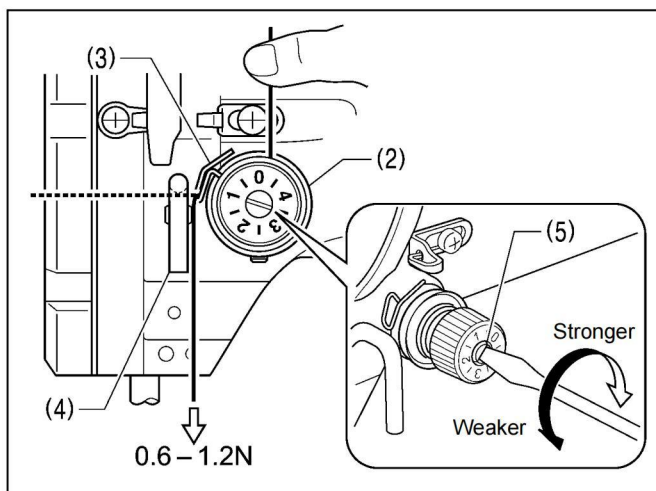

#### <Thread take-up spring tension>

1. Press the upper thread slightly above the tension bracket (2) with a finger to stop the thread spooling out.
2. Pull the upper thread downward so that the thread take-up spring (3) is extended to the same height as the base of the thread guide arm (4), and then measure the tension of the thread take-up spring (3).
3. Use a screwdriver to turn the tension stud (5) in order to adjust the tension of the thread take-up spring (3).

#### NOTE:

If the thread tension spring (3) is not adjusted correctly, the upper thread trailing length will be uneven after thread trimming.



### 8-2. Adjusting arm thread guide R

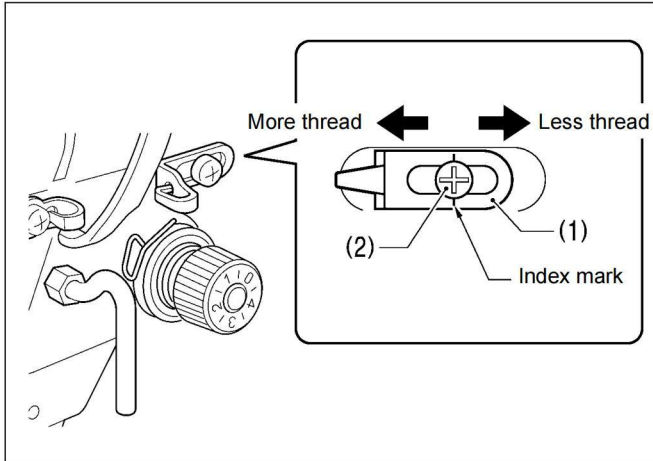

The standard position of arm thread guide R (1) is when the screw (2) is aligned with the index mark. Loosen the screw (2) and move arm thread guide R (1) to adjust.

- \* When sewing heavy material, move arm thread guide R (1) to the left. (The thread take-up amount will become greater.)
- \* When sewing light material, move arm thread guide R (1) to the right. (The thread take-up amount will become less.)

### 8-3. Adjusting the needle bar height

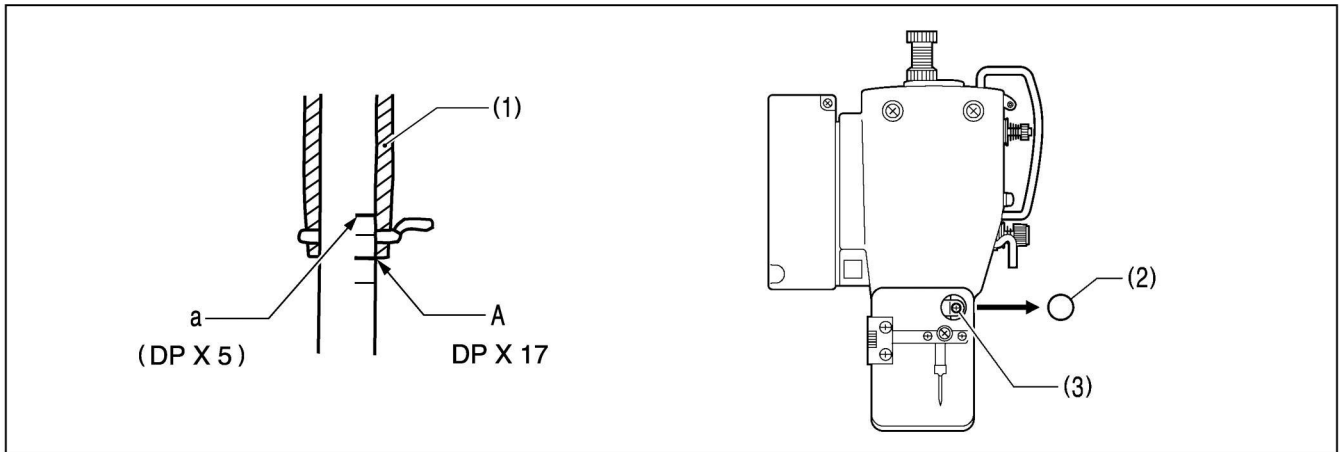

Turn the machine pulley to move the needle bar to the lowest position. Then remove the rubber plug (2), loosen the screw (3) and then move the needle bar up or down to adjust so that the second reference line from the bottom of the needle bar (reference line A) is aligned with the lower edge of the needle bar bush (1).

- \* If using a DP X 5 needle, use the highest reference line (reference line a).

### 8-4. Adjusting the needle bar lift amount

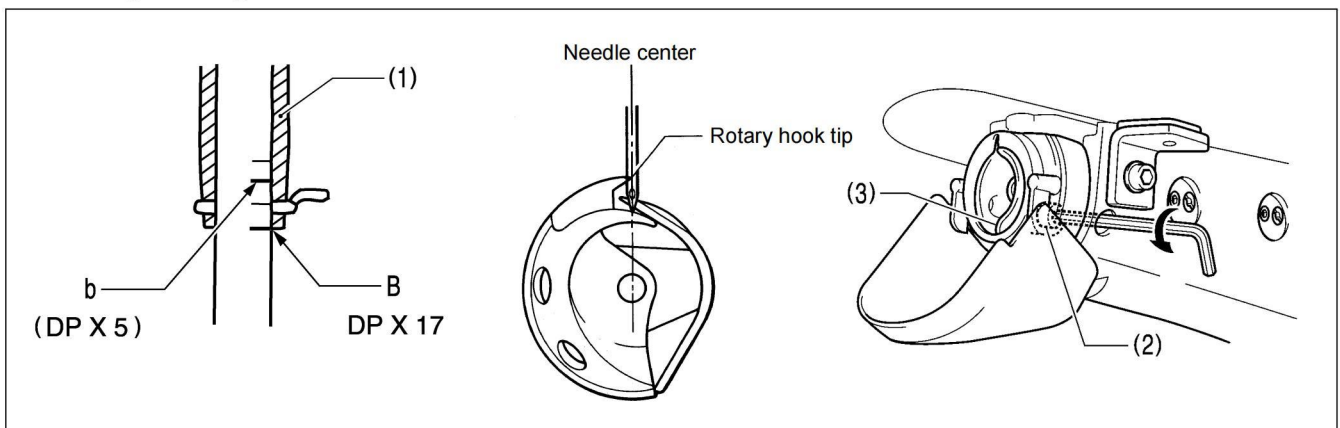

Turn the machine pulley to raise the needle bar from the lowest position until the lowest reference line on the needle bar (reference line B) is aligned with the lower edge of the needle bar bush (1), and then loosen the bolt (2) and move the driver (3) so that the tip of the rotary hook is aligned with the center of the needle.

- \* If using a DP X 5 needle, use the second reference line from the top of the needle bar (reference line b).

### 8-5. Adjusting the driver needle guard

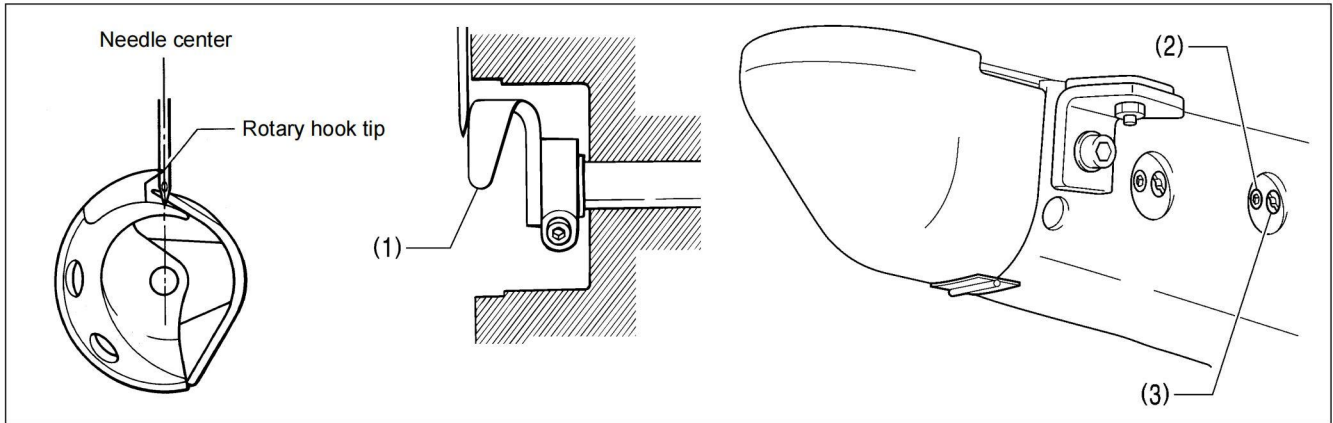

Turn the machine pulley to align the tip of the rotary hook with the center of the needle, and then loosen the set screw (2) and turn the adjusting stud (3) to adjust so that the driver needle guard (1) is touching the needle.

**NOTE:**

If it crosses the needle more than necessary, it will place a load on the needle, or it may cause poor thread tension. Furthermore, if it does not cross the needle at all, the tip of the rotary hook will interfere with the needle and skipped stitches may occur.

### 8-6. Adjusting the needle clearance

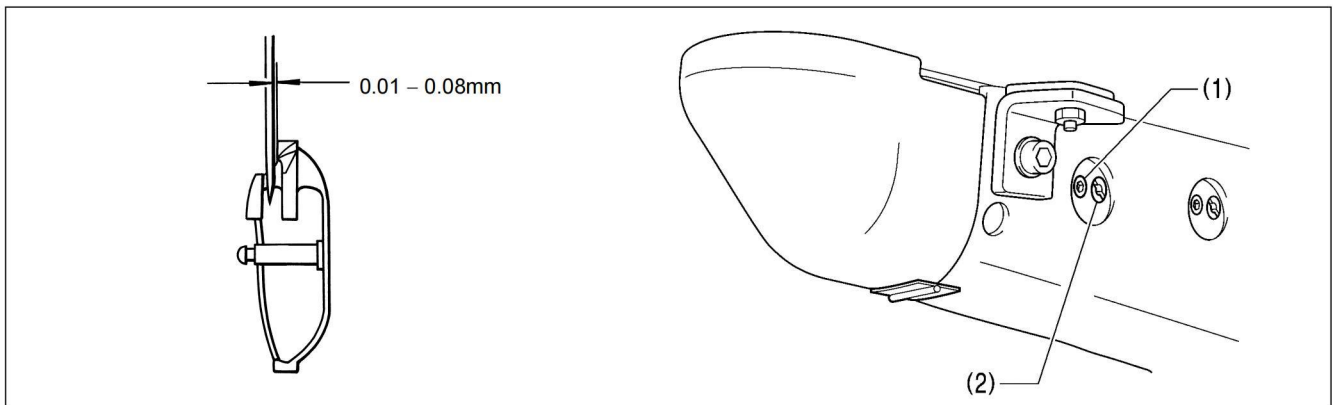

Turn the machine pulley to align the tip of the rotary hook with the center of the needle, and then loosen the set screw (1) and turn the adjusting stud (2) to adjust so that the clearance between the needle and the rotary hook is 0.01 – 0.08 mm.

### 8-7. Adjusting the shuttle race thread guide

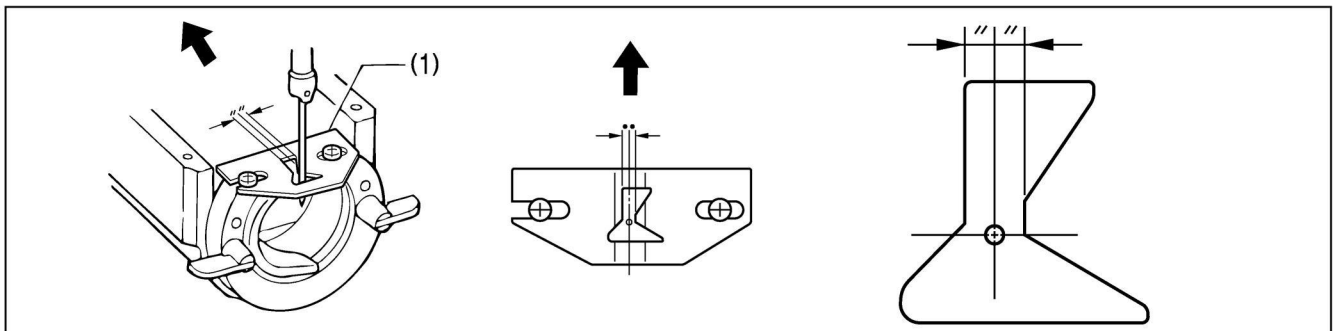

Install the shuttle race thread guide (1) by pushing it in the direction of the arrow so that the needle groove is aligned with the center of the needle plate hole.

**NOTE:**

If the shuttle race thread guide (1) is in the wrong position, thread breakages, soiled thread or tangling of the thread may occur. The position of the shuttle race thread guide (1) is adjusted at the time of shipment from the factory. It should not be changed if possible.

## 8-8. Adjusting the rotary hook lubrication amount

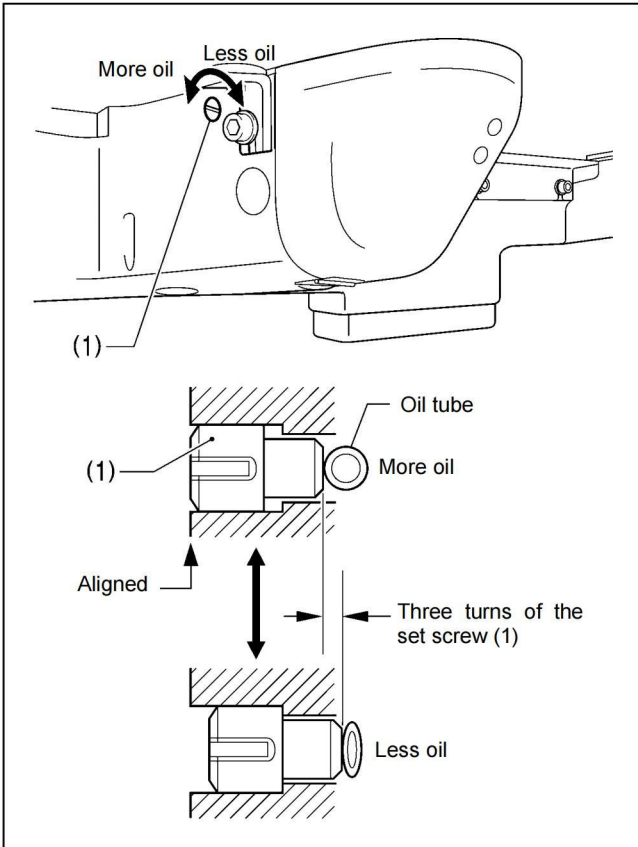

### <Adjusting by changing the pressure on the oil tube>

The optimum position is when the head of the set screw (1) is aligned with the edge of the bed. The rotary hook lubrication amount can be adjusted within three turns to the right from that position.

- If the set screw (1) is turned clockwise, the lubrication amount becomes smaller.
- If the set screw (1) is turned counterclockwise, the lubrication amount becomes greater.

\* If you would like the lubrication amount to be increased further from the position the head of the set screw (1) is aligned with the edge of the bed, use the following method to make the adjustment.

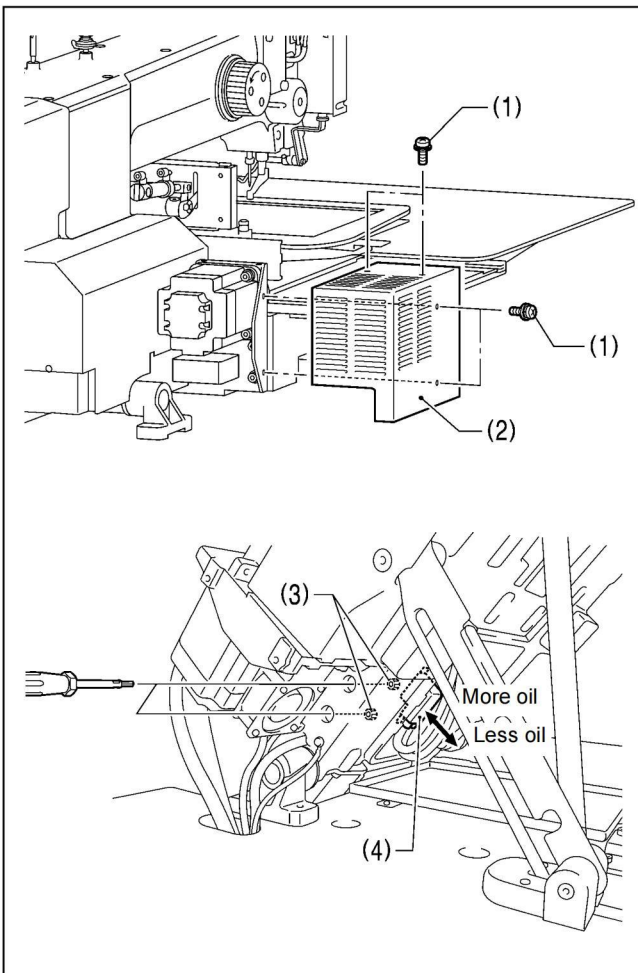

### <Adjusting by changing the amount of oil supplied from the sub-tank>

1. Remove the four screws (1), and then remove the X motor cover (2).

2. Tilt back the machine head.
3. Insert a screwdriver into the holes in the left side of the sewing machine bed and loosen the two bolts (3).
4. Move the sub-tank (4) up or down to adjust its position, and then tighten the two bolts (3).

- If the position of the sub-tank (4) is raised, the lubrication amount will increase.
- If the position of the sub-tank (4) is lowered, the lubrication amount will decrease.

5. Return the machine head to its original position.
6. Install the X motor cover (2) with the four screws (1).

### 8-9. Adjusting the position of the movable knife

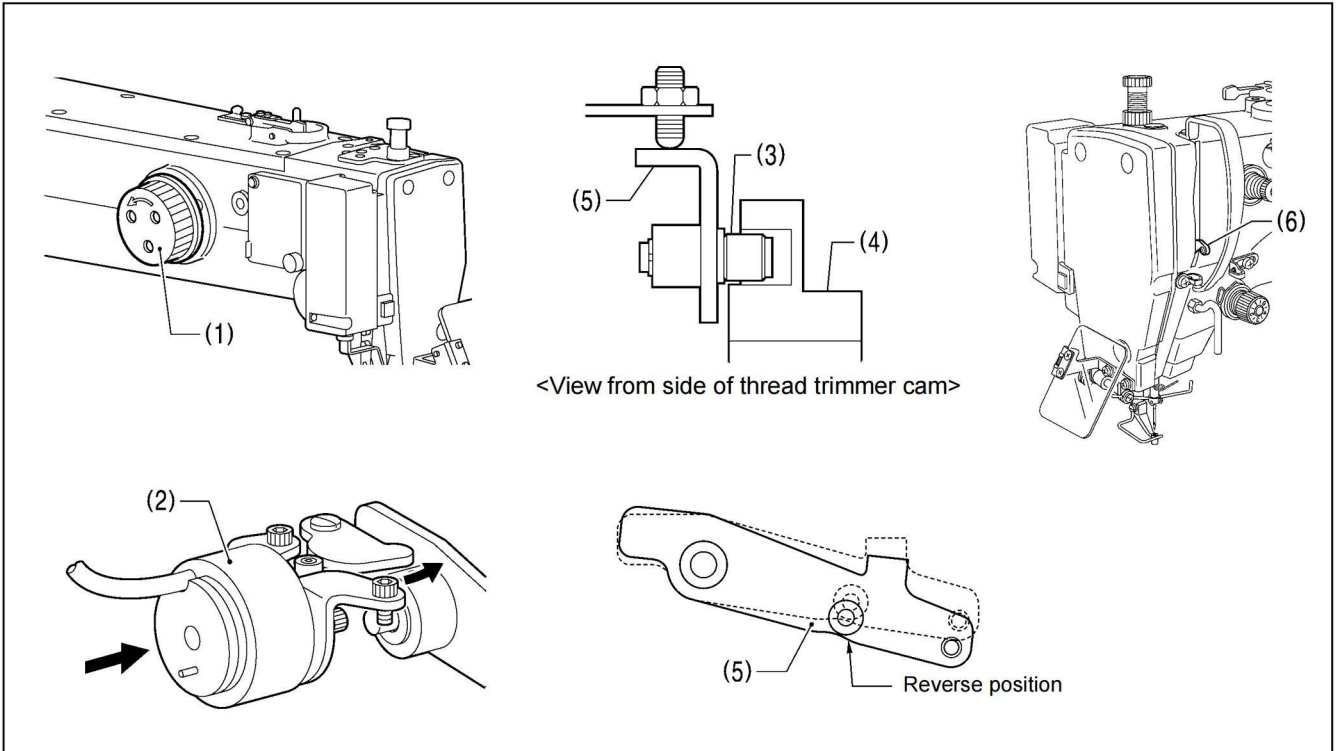

1. Open the top cover and tilt back the machine head.
2. Turn the pulley (1) by hand to lower the needle bar to its lowest position, and push the thread trimmer solenoid (2) as far as it will go.
3. With the collar (3) inserted into the groove of the thread trimmer cam (4), turn the pulley (1) by hand to set the driving lever (5) to the reverse position (when the thread take-up (6) is close to its lowest position).

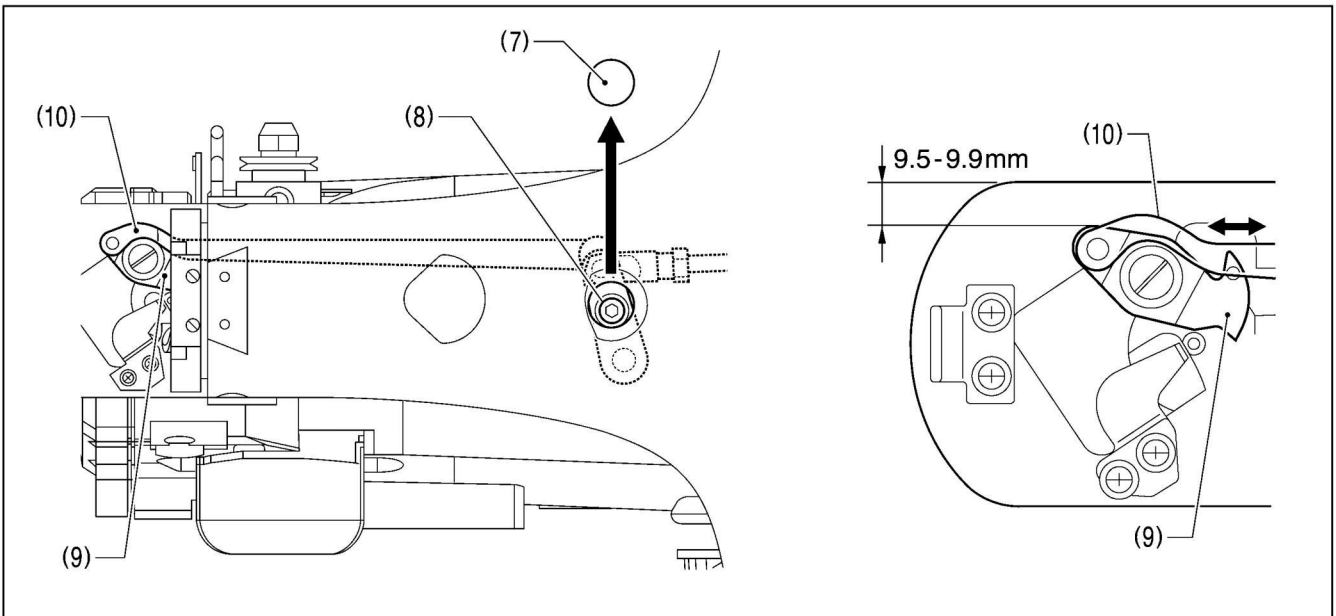

4. Remove the rubber cap (7).
5. Loosen the bolt (8).
6. Move the movable knife connecting plate (10) back and forth to adjust so that the distance from the ridge on the right side of the needle plate to the ridge on the movable knife (9) is 9.5 to 9.9 mm.
7. After tightening the bolt (8), check the above position once more.

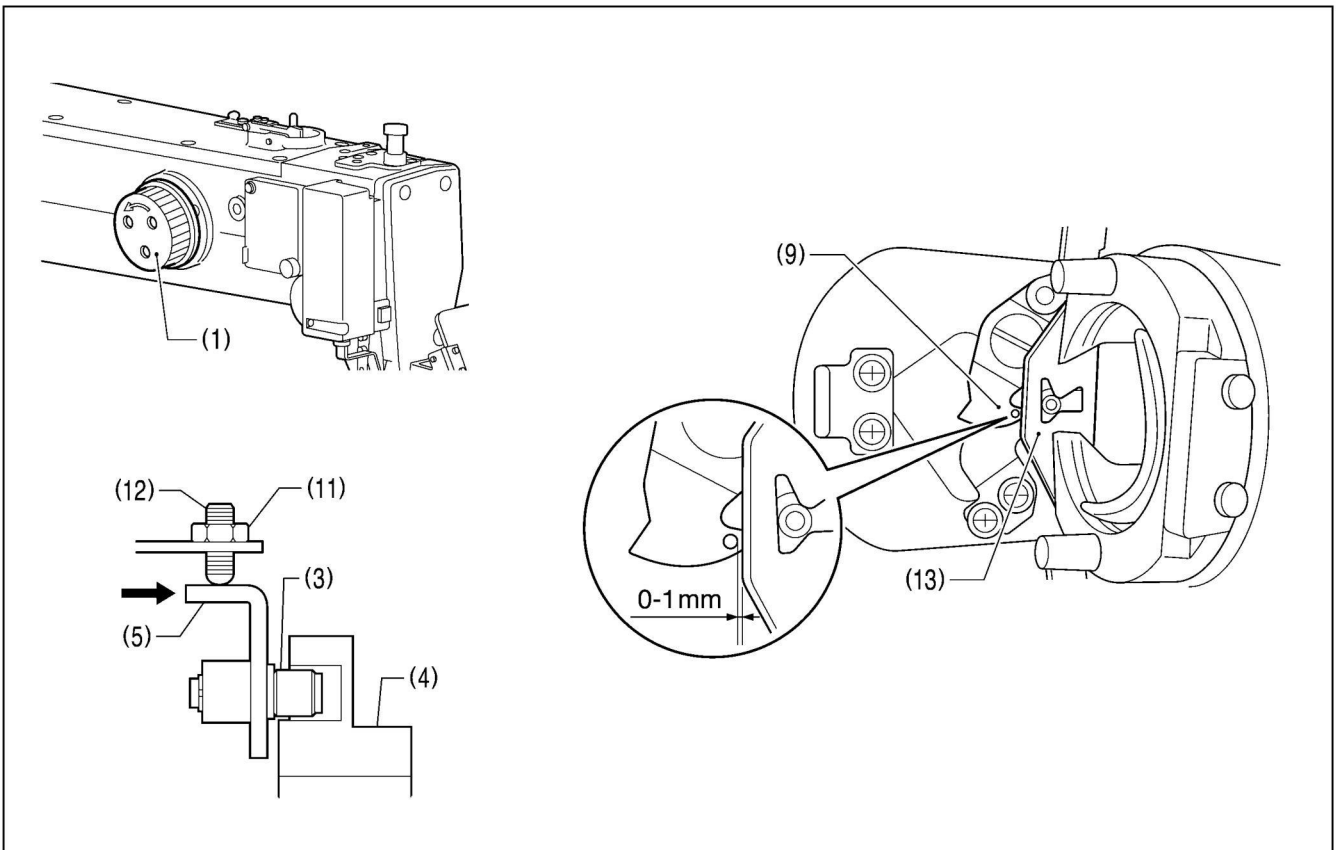

8. Turn the pulley (1) by hand to move the needle bar to its lowest position.
9. Loosen the nut (11), tighten the set screw (12) until the collar (3) is touching the inside of the groove in the thread trimmer cam (4), and then turn it back in the counterclockwise direction by approximately 1/4 of a turn.
10. Tighten the nut (11), and then check that the collar (3) is not touching the inside of the groove in the thread trimmer cam (4). In addition, push the driving lever (5) by hand toward the thread trimmer cam until the collar (3) touches the groove of the thread trimmer cam (4), and then check that the driving lever (5) returns smoothly to its original position when it is released.
11. Check that there is a gap of about 0 - 1 mm between the outside of the hole in the movable knife (9) and the ridge line on the shuttle race thread guide (13) when there is still play between the parts.

## 8-10. Replacing the movable and fixed knives

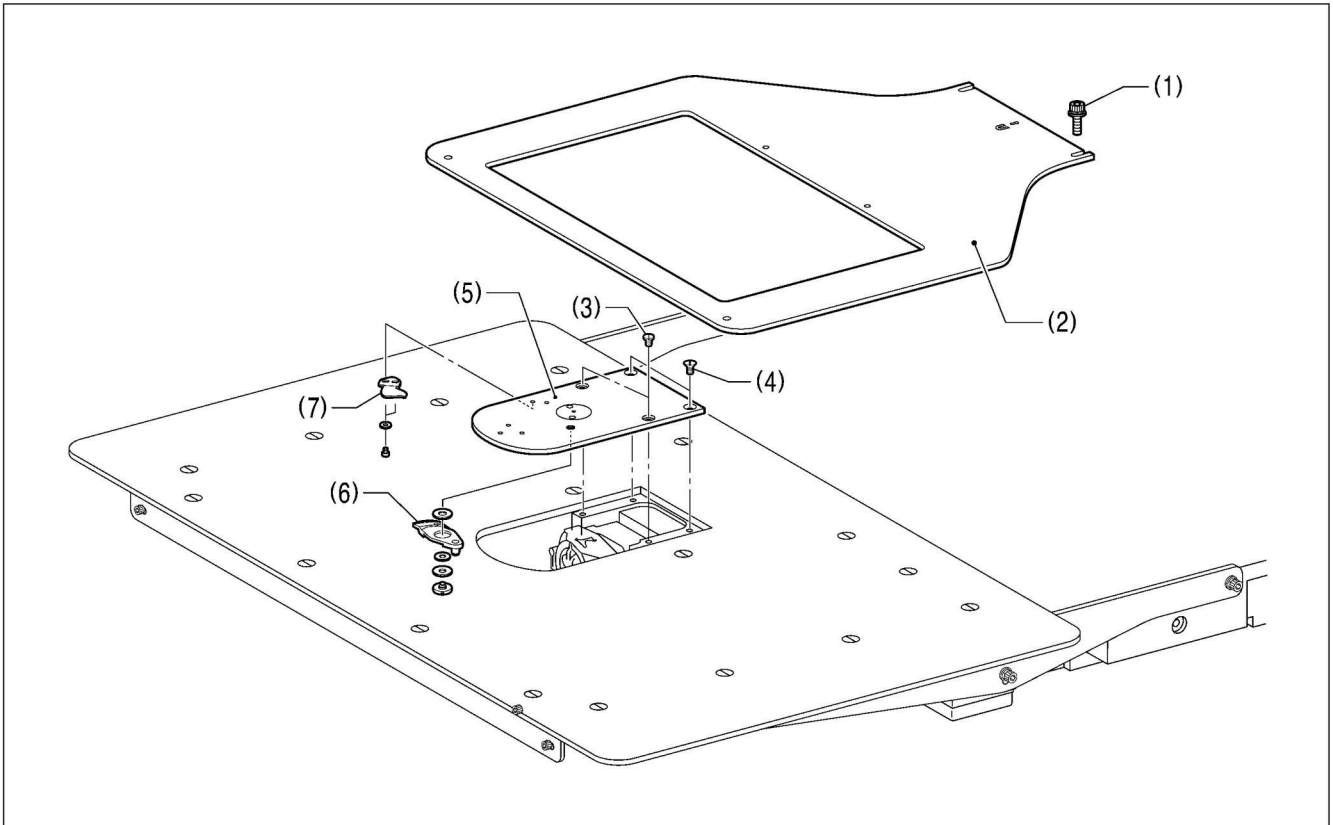

1. Loosen the two bolts (1) and then remove the feed plate (2).
2. Open the shuttle race cover, remove the two screws (3) and the two flat screws (4), and then remove the needle plate (5).
3. Remove the movable knife (6) and the fixed knife (7).

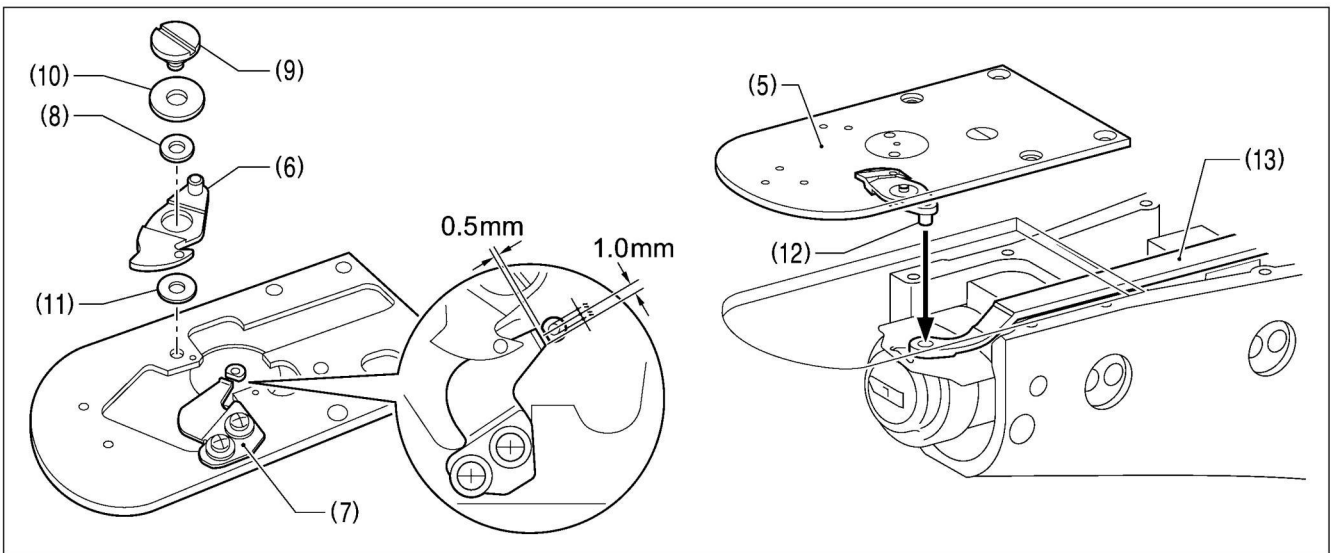

4. Install the new fixed knife (7) in the position shown in the illustration.
5. Apply grease to the outside of the collar (8) and to the shoulder screw (9), and then install the new movable knife (6) together with the thrust washer (10) and the movable knife spacer (11).
6. Check that the movable knife (6) and fixed knife (7) cut the thread cleanly. Replace the movable knife spacer with accessory spacers ( $t=0.2, 0.3, 0.4$ ) so that the knives trim the thread accurately.
  - \* If the knife pressure is too weak and the thread is not completely cut, use a thinner movable knife spacer.
  - \* If the knife pressure is too strong and the movable knife (1) turns stiffly, use a thicker movable knife spacer.
7. Apply grease to the pin (12), place it into the movable knife connecting plate (13), and install it to the needle plate (5).
8. Check that the needle is aligned with the center of the needle hole.
9. Install the feed plate (2). (Refer to the next page.)

## 8-10. Adjusting the thread wiper

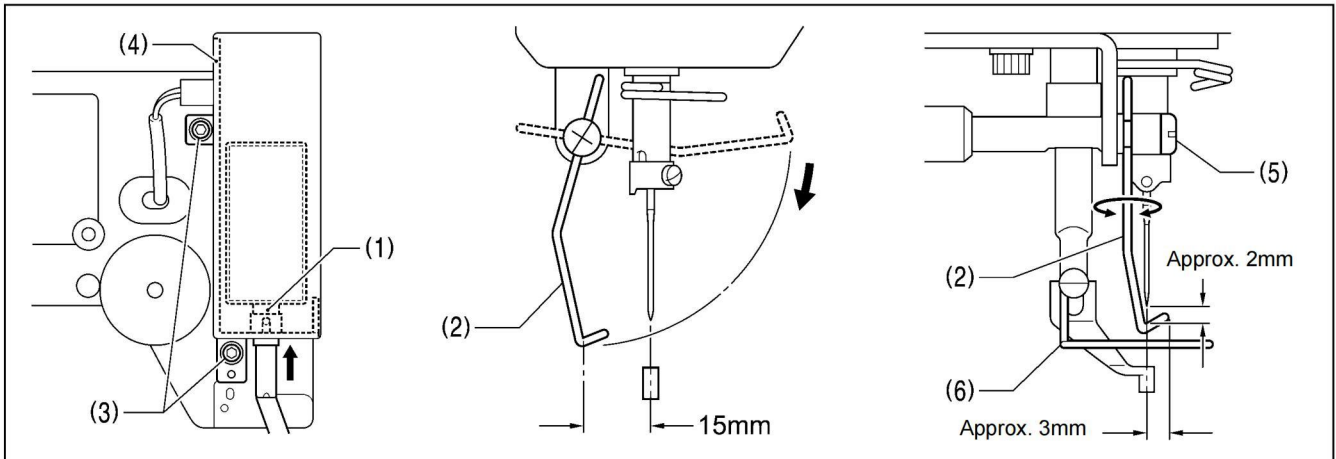

1. Loosen the two screws (3) and shift the entire solenoid setting plate (4) up or down to adjust so that the thread wiper (2) is 15 mm in front of the needle center when the plunger (1) of the thread wiper solenoid is driven to the full stroke.
2. Loosen the screw (5) and adjust the position of the thread wiper (2) so that the distance from the thread wiper to the tip of the needle is approximately 2 mm and the tip of the thread wiper (2) is approximately 3 mm from the center of the needle when the thread wiper (2) passes below the needle during operation.

**NOTE:**

Check that the thread wiper (2) does not touch the finger guard (6).

### 8-12. Presser foot installation position

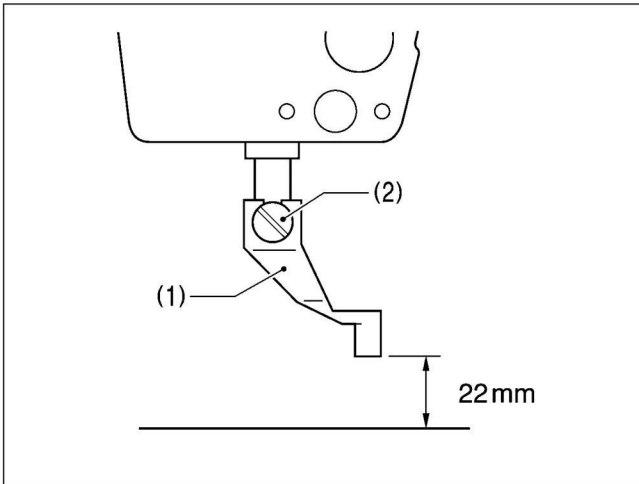

Install the presser foot (1) with the screw (2) so that the distance from the bottom of the presser foot to the top of the needle plate is 22 mm when the sewing machine is stopped and the presser foot (1) is raised.

### 8-13. Changing the intermittent stroke

The intermittent stroke can be adjusted to within 2 – 10 mm by adjusting the position of the stepping clamp connecting rod and changing the installation position of stepping clamp link A.

**<Changing the installation position of stepping clamp link A>**

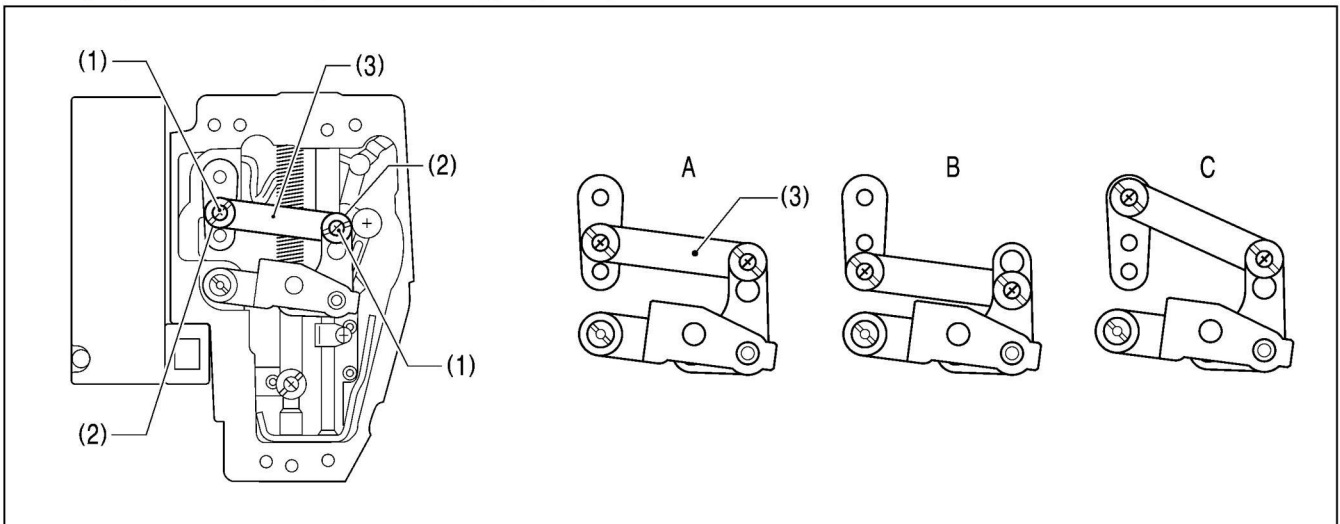

1. Remove the face plate.
  2. Remove the two screws (1) and the two shoulder screws (2), and then remove stepping clamp link A (3).
  3. Change the installation position for stepping clamp link A (3) to either A, B or C above.
- If the position of the stepping clamp connecting rod is adjusted as described in the following at any one of the installation positions, the adjustment range for the intermittent stroke will as given in the following table. (Refer to the next page.)

| Installation position | Intermittent stroke range                     |  |
|-----------------------|---|--|
| A                     | 2 – 4.5mm                                     |  |
| B                     | 4.5 – 10mm                                    |  |
| C                     | 0 mm (Presser foot does not move up and down) |  |



## &lt;Stepping clamp connecting rod position adjustment&gt;

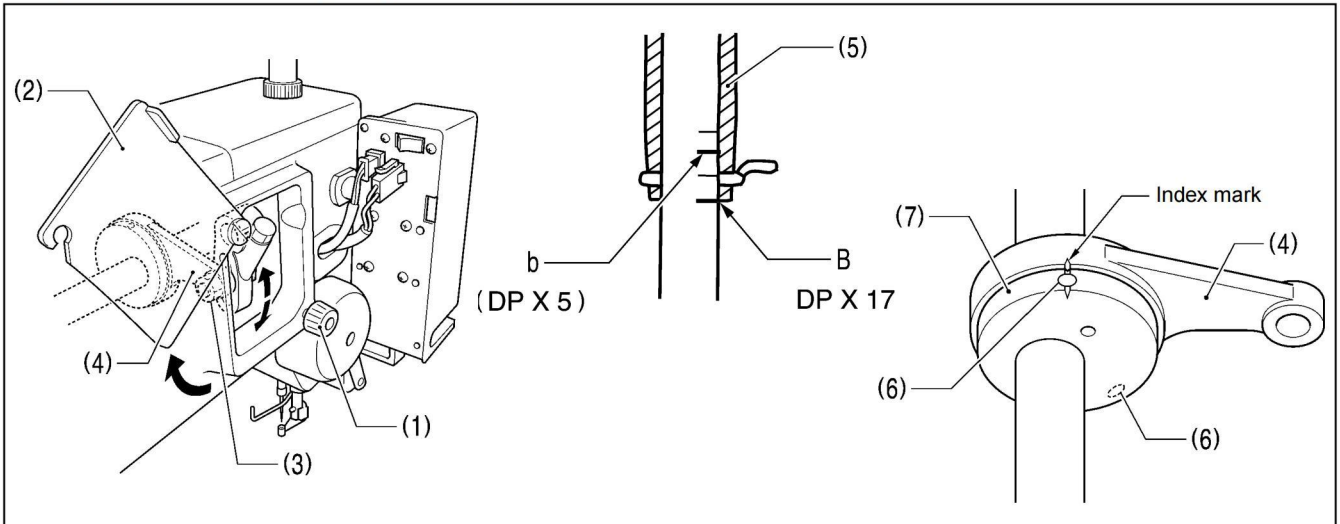

1. Loosen the screw (1), and then open the cover (2).
2. Loosen the nut (3), and then adjust the position of the stepping clamp connecting rod (4).
  - When the stepping clamp connecting rod (4) is raised, the intermittent stroke will increase.
  - When the stepping clamp connecting rod (4) is lowered, the intermittent stroke will decrease.

Next, adjust the needle bar and presser foot timing.

3. Turn the machine pulley to raise the needle bar from the lowest position until the lowest reference line on the needle bar (reference line B) is aligned with the lower edge of the needle bar bush (5).  
(If using a DP x 5 needle, align with the second reference line from the top (reference line b).)
4. Open the top cover and loosen the two set screws (6).
5. Align the index marks on the stepping clamp cam (7) and the stepping clamp connecting rod (4), and then tighten the set screws (6).

Check the following after changing the intermittent stroke.

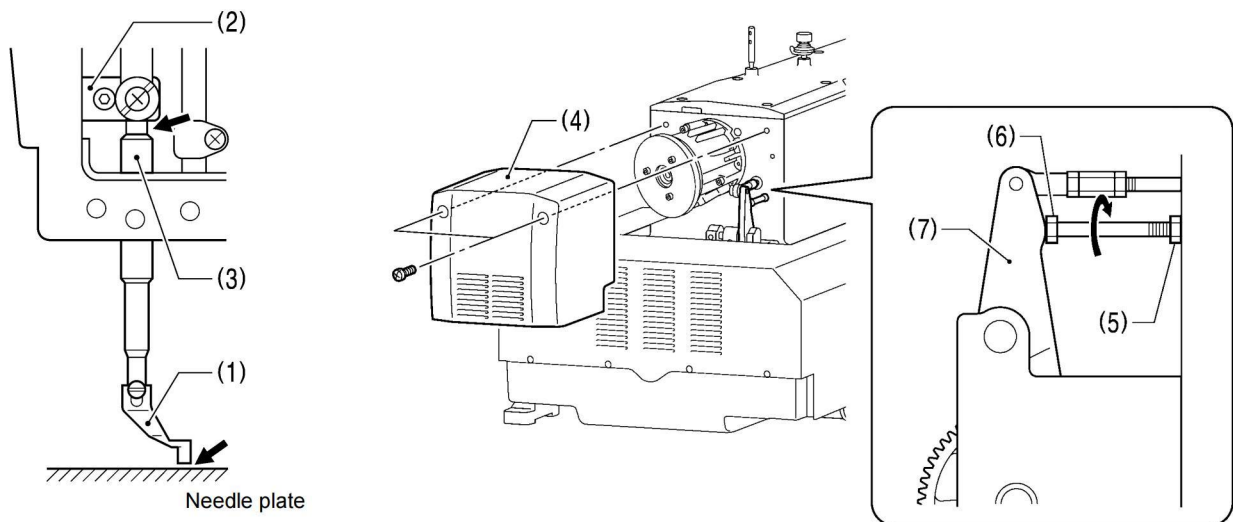

1. With the intermittent presser foot (1) lowered, turn the pulley to move the intermittent presser foot (1) to its lowest position.
2. Check that the presser foot (1) does not touch the needle plate and that the presser bar clamp (2) does not touch the presser bar bush (3).

## &lt;If they are touching&gt;

Remove the motor cover (4).

Loosen the nut (5), and turn the bolt (6) until it is pressing against the intermittent drive lever (7), and then adjust until the two points mentioned above are not touching.

## 8. STANDARD ADJUSTMENTS

### 8-14. Adjusting the work clamp lift amount

The maximum lift amount for the work clamp (2) is 30 mm above the top of the needle plate.

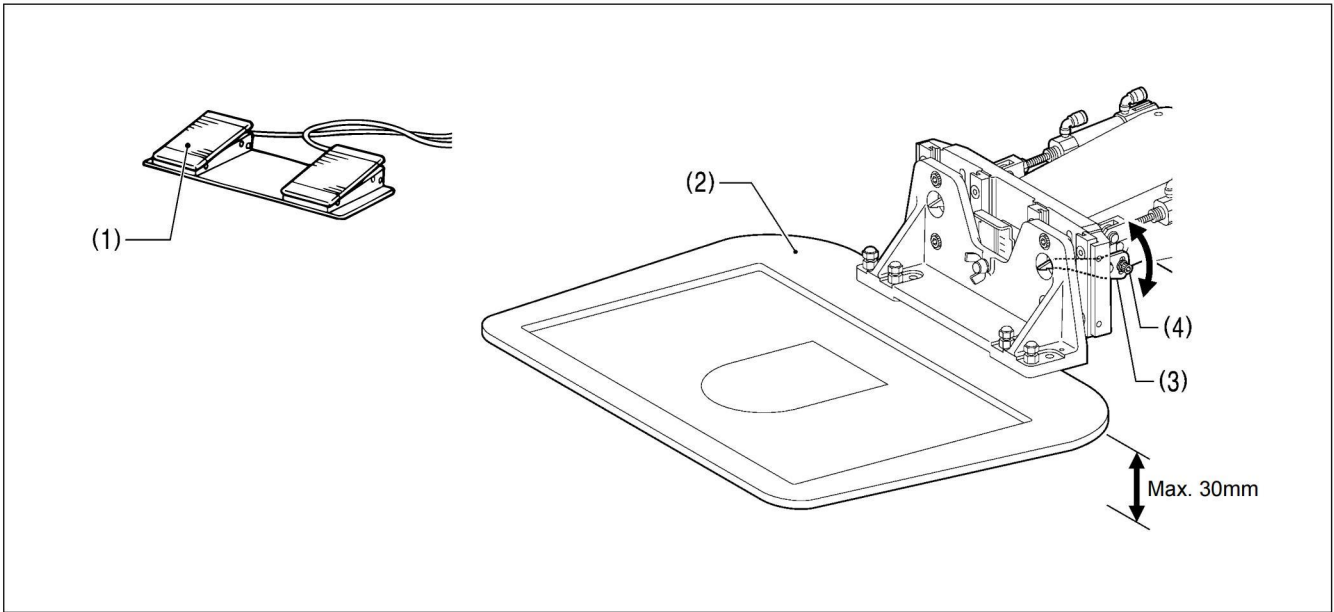

1. Turn on the air, and then turn on the power switch.
2. Depress the work clamp switch (1) to raise the work clamp (2).
3. Loosen the two bolts (4) of the work clamp lifter lever (3), and then move the work clamp lifter lever (3) up or down to adjust the lift amount.

### 8-15. Adjusting the air pressure

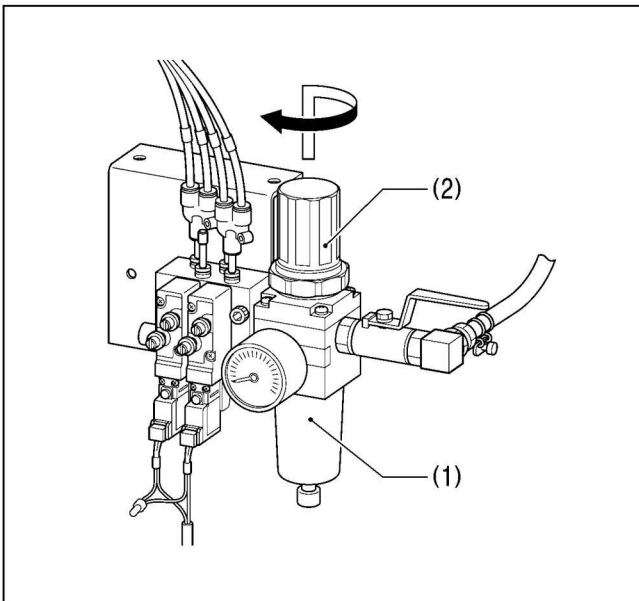

Lift up the handle (2) of the regulator (1) and then turn it to adjust the air pressure to 0.5 MPa. After adjustment is complete, push the handle (2) downward to lock it.

## 9. TROUBLESHOOTING

- Please check the following points before calling for repairs or service.
- If the following remedies do not fix the problem, turn off the power switch and consult a qualified technician or the place of purchase.

### CAUTION



Turn off the power switch and disconnect the power cord before carrying out troubleshooting.  
If the foot switch is depressed by mistake, the sewing machine might start operating and injury could result.

| Problem  | Cause   | Remedy   | Reference |
|--|---|--|-----------|
| <b>Work clamp does not lift.</b>                       | Work clamp moves stiffly.                               | Apply a suitable amount of grease to the sliding parts of the work clamp slider. |           |
| <b>Work clamp does not drop.</b>                       | Air tube of presser lifter cylinder is bent or damaged. | Straighten the bend in the tube or replace the tube.                             |           |
| <b>Work clamp lift amount is incorrect.</b>            | Work clamp lifter lever position is incorrect.          | Adjust the position of the work clamp lifter lever.                              | P. 33     |
| <b>Work clamp does not lift to the maximum height.</b> | Cylinder joint position is incorrect.                   | Adjust the position of the cylinder joint.                                       |           |
| <b>Thread wiper does not operate correctly.</b>        | The thread wiper is obstructing the needle.             | Adjust the height of the thread wiper.   | P. 30     |
|  |   | Adjust the stroke of the thread wiper.   | P. 30     |
|  | Thread wiper position is incorrect.                     | Adjust the stroke of the thread wiper.   | P. 30     |
| <b>Lower thread winds to one side.</b>                 | Bobbin winder tension assembly height is incorrect.     | Adjust the height of the bobbin winder tension assembly.                         | P. 16     |
| <b>Lower thread winding amount is incorrect.</b>       | Bobbin presser position is incorrect.                   | Adjust the position of the bobbin presser.                                       | P. 16     |
| <b>Thread slips out of the needle.</b>                 | Stitches being skipped at the sewing start.             | Refer to "Skipped stitches occur".   | P. 35     |
|  | Upper thread trailing length is uneven.                 | Adjust the sub-tension.  | P. 18     |
|  | Position of shuttle race thread guide is incorrect      | Adjust the position of the shuttle race thread guide.                            | P. 25     |

## 9. TROUBLESHOOTING

| Problem                        | Cause  | Remedy  | Reference |
|--------------------------------|--|---|-----------|
| <b>Upper thread breaks.</b>    | Upper thread tension is too strong.                                | Adjust the upper thread tension.  | P. 18     |
|                                | Needle is incorrectly installed.                                   | Install the needle correctly.   | P. 13     |
|                                | Thread is too thick for the needle.                                | Select a thread that matches the needle.  | P. 18     |
|                                | Thread take-up spring tension and height are incorrect.            | Adjust the tension and height of the thread take-up spring.                             | P. 23     |
|                                | Damage or burring of the rotary hook, needle hole plate or needle. | Repair or replace the problem part.   |           |
|                                | Thread breaking from heat (Synthetic thread)                       | Use a cooling tank.   | P. 14     |
|                                | Thread is threaded incorrectly.                                    | Thread the thread correctly.  | P. 14     |
| <b>Lower thread breaks.</b>    | Lower thread tension is too strong.                                | Adjust the lower thread tension.  | P. 18     |
|                                | Damage to corners of needle hole plate or bobbin case.             | Repair or replace the problem part.   |           |
| <b>Skipped stitches occur.</b> | Clearance between needle and rotary hook tip is too great.         | Adjust the needle clearance.  | P. 25     |
|                                | Needle and rotary hook timing is incorrect.                        | Adjust the needle bar lift amount.  | P. 24     |
|                                | The driver is covering the needle more than necessary.             | Adjust the driver needle guard.   | P. 25     |
|                                | Needle is bent.  | Replace the needle.   |           |
|                                | Needle is incorrectly installed.                                   | Install the needle correctly.   | P. 13     |
| <b>Needle is broken.</b>       | Clearance between needle and rotary hook tip is too great.         | Adjust the needle clearance.  | P. 25     |
|                                |  | Adjust the needle bar lift amount.  | P. 24     |
|                                | Needle is bent.  | Replace the needle.   |           |
|                                | Needle deflection  | Select a needle that is suitable for the sewing conditions.<br>Reduce the sewing speed. | P. 18     |
|                                | Needle is too thin.  | Select a needle that is suitable for the sewing conditions.                             | P.18      |
| <b>Thread jamming.</b>         | Thread take-up spring tension and height are incorrect.            | Adjust the tension and height of the thread take-up spring.                             | P. 23     |
|                                | Needle and rotary hook timing is incorrect.                        | Adjust the needle bar lift amount.  | P. 24     |
|                                | Shuttle race thread guide is not separating the threads.           | Adjust the position of the shuttle race thread guide.                                   | P. 25     |

| Problem  | Cause  | Remedy   | Reference |
|--|--|--|-----------|
| <b>Upper thread is not trimmed.</b>  | Movable knife is not cutting cleanly.  | Replace with a new one.  | P. 29     |
|  | Fixed knife is not cutting cleanly.  | Sharpen the fixed knife or replace it with a new one.              | P. 29     |
|  | Movable knife is not picking up the upper thread.  | Adjust the position of the shuttle race thread guide.              | P. 25     |
|  |  | Adjust the needle bar lift amount.                                 | P. 24     |
|  | Movable knife is not picking up the upper thread because the last stitch is being skipped. | Refer to "Skipped stitches occur".                                 | P. 35     |
|  | Movable knife position is incorrect.   | Adjust the position of the movable knife.                          | P. 27     |
|  | Sub-tension is too weak.   | Turn the sub-tension nut to adjust the tension.                    | P. 18     |
| <b>Poor stitch finish on underside of material.</b>  | Shuttle race thread guide is not separating the threads enough.                            | Adjust the position of the shuttle race thread guide.              | P. 25     |
|  | Incorrect tightening of the upper thread   | Adjust the upper thread tension.                                   | P. 18     |
|  | Upper thread trailing length is uneven.  | Adjust the sub-tension.  | P. 18     |
| <b>Incorrect tightening of the thread</b>  | Upper thread tension is too weak.  | Adjust the upper thread tension.                                   | P. 18     |
|  | Lower thread tension is too weak.  | Adjust the lower thread tension.                                   | P. 18     |
|  | Thread take-up spring tension and height are incorrect.                                    | Adjust the tension and height of the thread take-up spring.        | P. 23     |
|  | Position of arm thread guide R is incorrect.   | Adjust the position of arm thread guide R.                         | P. 24     |
| <b>Upper thread trailing length is uneven.</b>   | Thread take-up spring tension and height are incorrect.                                    | Adjust the tension and height of the thread take-up spring.        | P. 23     |
|  | Sub-tension is too weak.   | Turn the sub-tension nut to adjust the tension.                    | P. 18     |
|  | Fixed knife is not cutting cleanly.  | Sharpen the fixed knife or replace it with a new one.              | P. 29     |
| <b>Sewing machine does not operate when the power is turned on and the foot switch is depressed.</b> | Safety switch does not work.   | Check if the safety switch cord is disconnected.                   |           |
|  |  | Adjust the position of the safety switch.                          | P. 12     |
|  |  | If the safety switch is malfunctioning, replace it with a new one. |           |